

Blackmagic URSA Mini

The world's lightest handheld
Super 35 digital film camera



Introducing URSA Mini, a lightweight miniaturized URSA featuring an incredible 4.6K Super 35 image sensor with global shutter and a massive 15 stops of dynamic range! The super compact and lightweight design is perfectly balanced for

handheld use and comfortable enough for all day shooting. That means you get a handheld camera with higher resolution and better dynamic range than most Super 35mm film! URSA Mini shoots up to 60 frames per second, has a super bright 5

inch foldout viewfinder, dual RAW and ProRes recorders and more. You can select from four models of URSA Mini with 4.6K

or 4K image sensors and either EF or PL lens mounts.



Handheld Digital Film Camera

Perfect for feature film, television
production and more!

Blackmagic URSA Mini is designed to be used on feature films,

television shows, commercials, indies, documentaries, music videos and more. The stunning quality of its 4.6K sensor with 15 stops of dynamic range lets you capture epic cinematic shots, while its compact size is perfect for solo shoots or smaller crews! You can easily customize URSA Mini with high quality cinema lenses, rails, matte boxes and more. The optional shoulder mount kit features a quick release mounting plate so you can go from handheld to shoulder or tripod in seconds, making it perfect for pickup and run shooting situations. It's the handheld Super 35mm digital film camera that you can use anywhere and, because it's an URSA, everything you need is built right in!

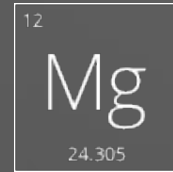

Magnesium
Body

Revolutionary URSA Design

All the big camera features you need built into a lightweight, portable design

URSA Mini features a compact, perfectly balanced body made out of advanced technology magnesium alloys so it's rugged, lightweight and comfortable enough to be used all day. Like all URSA cameras, it includes everything you need built right in! You get a super bright 5 inch fold out 1080 HD touch screen for on-set monitoring and to change camera settings, professional connectors such as 12G-SDI, a high quality stereo microphones and a side grip with control buttons mounted on a standard rosette. The optional Blackmagic viewfinder and shoulder mount kit allow you to go from tripod to over the shoulder shooting in seconds, so you can keep up with the action!



Highly Customizable

Flexible enough to be rigged for any production

Blackmagic URSA Mini is completely customizable so you can create a rig that's built specifically for your production! You can add accessories like the Blackmagic URSA Viewfinder and Blackmagic URSA Mini Shoulder Kit, or choose from hundreds of third party accessories. URSA Mini has 9 standard 1/4" threaded mounting points on the top and bottom of the camera so you can mount it directly to a tripod as well as add accessories such as rails, sliders, matte boxes, microphones, ring lights, batteries and more. Whether you're building a feature film rig or outfitting the camera for an ENG style shoot, URSA Mini has all of the mount points and connections you need!

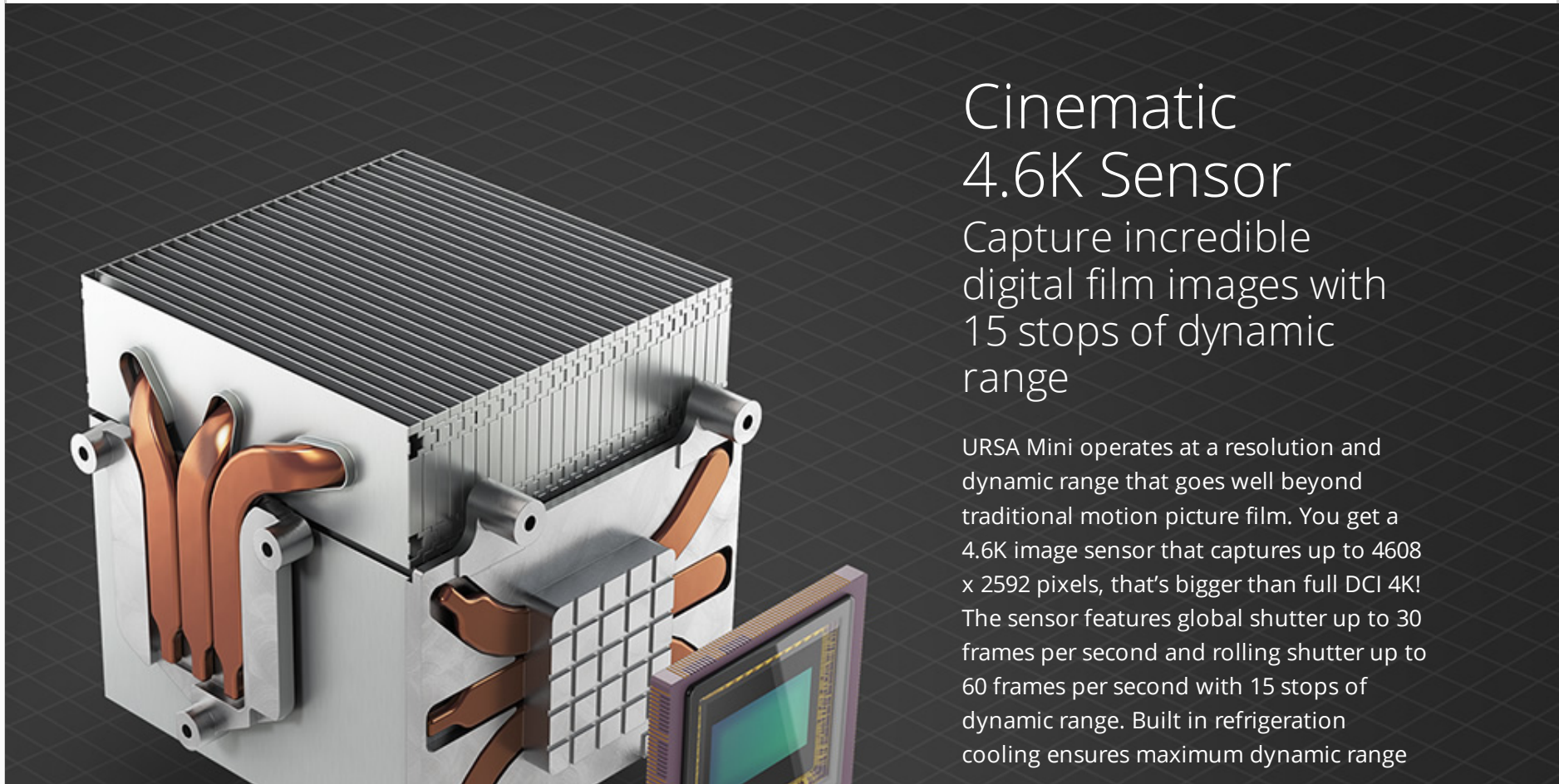

Cinematic 4.6K Sensor

Capture incredible
digital film images with
15 stops of dynamic
range

URSA Mini operates at a resolution and dynamic range that goes well beyond traditional motion picture film. You get a 4.6K image sensor that captures up to 4608 x 2592 pixels, that's bigger than full DCI 4K! The sensor features global shutter up to 30 frames per second and rolling shutter up to 60 frames per second with 15 stops of dynamic range. Built in refrigeration cooling ensures maximum dynamic range

High Frame Rate Recording

Capture the action with crystal clear slow motion

URSA Mini can shoot at high frame rates and then play it back at the edit frame rate so you get smooth slow motion video. Simply set the sensor frame rate to get different types of slow motion effects. URSA Mini can capture full resolution 4.6K recordings at up to 60 frames per second and up to 120 frames per second in regular 1080 HD! When you need even more dramatic, higher frame rate slow motion shooting, you can use the regular URSA which can record high resolution 4.6K images at an amazing 100 frames per second!



Ultra HD windowing of the sensor enables 1080 HD footage to be captured at up to 120fps!



URSA Mini 4680 x 2592

Ultra HD 3840 x 2160

HD 1920 x 1080



Stunning Ultra HD

Higher resolution creates smooth vivid Ultra HD images

Because URSA Mini features a 4.6K native resolution image sensor it can capture much higher resolution than Ultra HD. This means when you're working in Ultra HD you have a lot of extra resolution that can be

used through the de-bayering image processing so you can recover full color for incredible images. The wide dynamic range blows away high end broadcast cameras to give you dramatically better images that can be color corrected for a truly cinematic look. For faster post production, quickly switch settings to use regular video dynamic range, so you can shoot great looking video without the need for color correction.



Non Stop Recording

Change memory cards
even while recording

Blackmagic URSA Mini features dual CFast 2.0 recorders so you never have to stop recording when you need to change the media! When the current card is full, recording continues onto the second card so you can swap out the full card and just keep shooting. URSA Mini uses the latest, incredibly fast CFast 2.0 technology for recording speeds up to 350 MB/s. You get perfect high frame rate RAW recording and instant play back on the built in 5 inch screen. Files can be saved as lossless 12-bit CinemaDNG RAW for the highest possible quality, or as ProRes for easy post production workflows with minimum storage requirements!



Blackmagic URSA Mini
D4 Mount

If you already have an investment in incredible high definition B4 lenses, now you can use them with URSA Mini PL by adding the optional B4 lens mount. Unlike lens adapters, you can actually replace the lens mount itself to get a B4 mount with precision optics and spherical aberration correction specifically designed to match URSA Mini's sensor! The B4 mount turns your URSA Mini into an incredibly compact HD camera with better dynamic range and support for more modern file formats than any other broadcast camera! The built in lens control connection provides power, start/stop recording and lens control for the lens. With the Blackmagic URSA Mini B4 Mount you can easily move between B4 and PL lenses any time you need.



High Resolution Viewfinder

Full HD display and glass optics makes precise focus easy

The optional Blackmagic URSA Viewfinder has been designed to be the perfect match for URSA and URSA Mini digital film cameras. The Blackmagic URSA Viewfinder has the

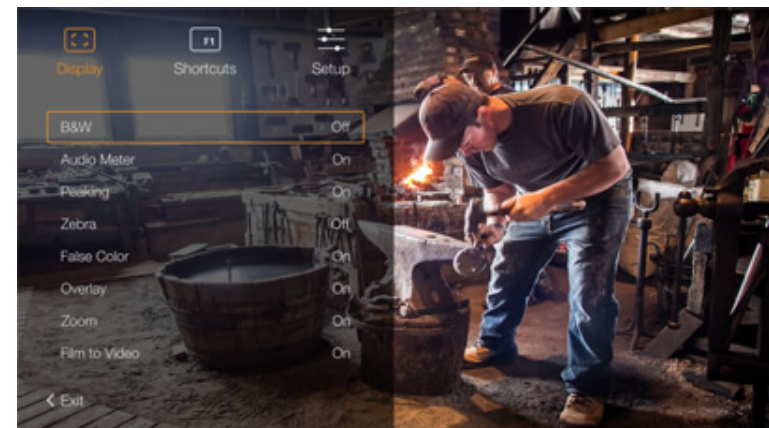

specifications demanded by high end cinematographers. You get a high resolution 1920 x 1080 color OLED display matched with precision glass optics, adjustable diopter and built in digital focus chart so you get perfect focus every time. To preserve OLED screen life there's a built in sensor so the OLED only turns on when you're looking through the viewfinder. The Blackmagic URSA Viewfinder is adjustable so it can be used on both the left or the right eye. There's even a built in record light!

Touchscreen Control

Change settings and monitoring with the touch of your finger

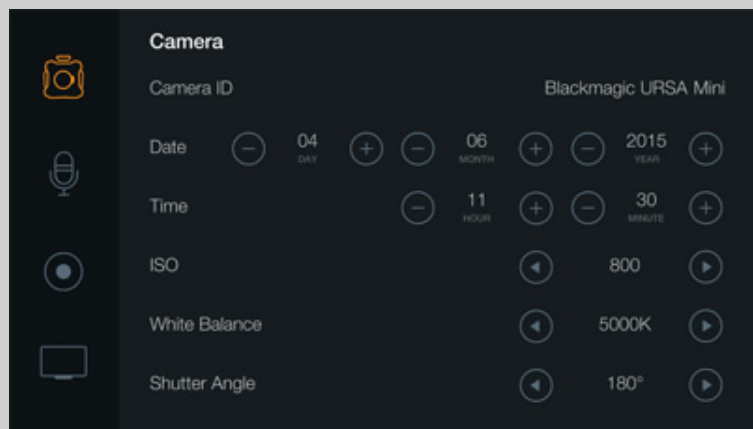

The high resolution 5 inch fold out monitor includes a touchscreen so you get easy access to the revolutionary URSA camera interface. All of your settings, controls and monitoring tools are at your fingertips. That means you don't have to hunt through confusing menus to make changes. You can see and change all camera settings, view timecode, histograms for checking levels, audio levels and a focus peaking indicator for checking focus!

Professional Connections

All the connections you need for virtually any use!

Blackmagic URSA Mini features multiple connections such as 12G-SDI out, HD-SDI monitoring out, 2 LANC inputs, balanced XLR audio with phantom power, timecode in and reference input. On the front right side of the camera the 4 pin XLR DC and HD-SDI monitoring output are located in the perfect position for connecting to an optional viewfinder or on set monitor. The 12G-SDI output handles up to 2160p60 using a single BNC cable and also switches to 6G-SDI or HD-SDI depending on the shooting format.

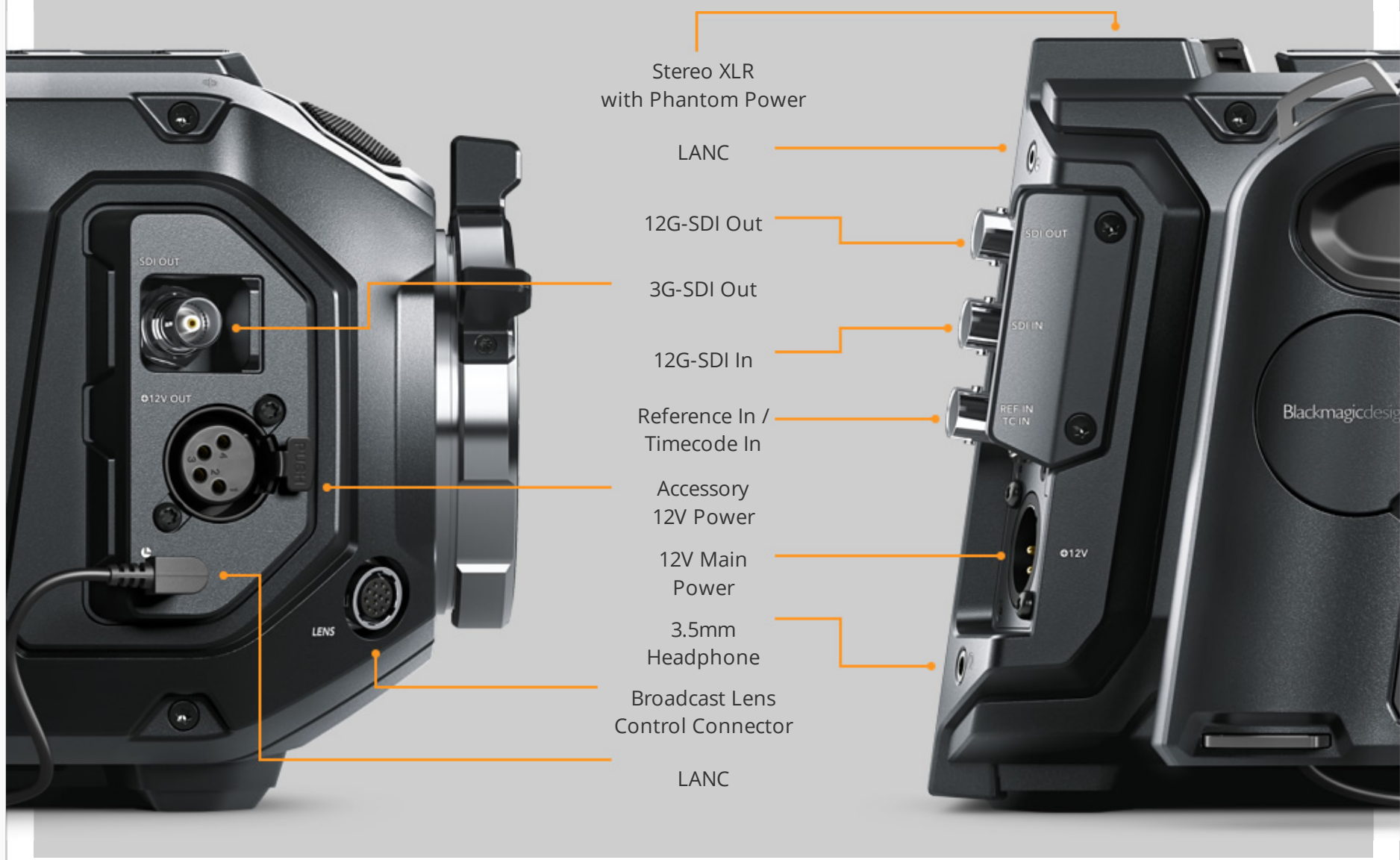

Advanced 12G-SDI

Get the latest in SDI video technology

Video: 2160p60, Rate: 12Gb/s **12G SDI**

Video: 2160p30, Rate: 6Gb/s **6G SDI**

Video: 1080p, Rate: 2.97Gb/s **3G SDI**

12G-SDI is an incredible 8 times faster than regular HD-SDI which makes it fast enough for Ultra HD video at up to 60 frames per second, all over a single regular SDI cable! The high quality BNC connections are multi rate so it can automatically switch and work with 6G-SDI, 3G-SDI, and regular HD-SDI equipment. That means URSA Mini is compatible with all of your existing HD and Ultra HD equipment so you can plug it into things like ATEM live production switchers, on-set monitors, decks and more!



Professional Audio

Built in production quality sound recording

URSA Mini has the highest quality built in microphones and professional audio recording built in so you don't have to carry around extra sound equipment. Use the built in stereo microphone to record natural location sound or connect professional microphones using the two XLR wide dynamic

range mic inputs. The XLR connections have 48V of switchable phantom power so you can plug in everything from shot gun to wireless clip on mics for capturing every detail of the performance. You can quickly adjust levels using the physical knobs and monitor audio using the onscreen audio meters.

The screenshot displays the camera's control interface. On the left, a virtual keyboard is overlaid on the screen, with the 'K' key highlighted. The keyboard includes a 'Cancel' button, a 'Space' bar, and an 'Enter' key. The main interface area is dark with white text. At the top left, the 'Comments' section contains the text: "Low tracking shot of Hero riding away from camp. Need to add dust and wagons. Note Hero has no pack on - continuity to check". To the right, the 'PROJECT NAME' is "The Redemption Trail" with a star icon. Below this, the metadata fields are: REEL: 002, SCENE: 6 (with a refresh icon), SHOT: 102 (with a refresh icon), TAKE: 34 (with a refresh icon), and ANGLE: LHCU. The 'COMMENTS' section is repeated below the metadata. At the bottom, the 'KEYWORDS' field contains "Prairie, Sunset, Hero, Camp, Horses" and a 'Save' button is visible on the right.

Embedded Metadata

Store location, camera orientation, scene details and more

The built in touchscreen makes it astonishingly simple to set up and enter metadata for tagging clips. Metadata is saved directly in the video files so you don't have to worry about managing extra sidecar files. You can import the files directly into software like DaVinci Resolve, Final Cut Pro and Avid Media Composer then use the metadata to sort, search and find the clips you need so you can spend more time on creative editing and less time managing mountains of media!



Optional Shoulder Mount Kit

From tripod to shoulder and back in seconds

URSA Mini includes multiple ¼" mount points on the bottom so you can attach it directly to any tripod. When you need to rapidly move URSA Mini from tripod to handheld and back multiple times on a shoot the best solution is to use the optional Blackmagic URSA Mini Shoulder Kit. This kit includes the shoulder pad with built in rosettes, rail mounts and integrated quick lock release attachment points so you can instantly latch it into the quick release plate without needing to remove the shoulder pad. The kit also includes a top handle for carrying the camera and attaching accessories.



trimming tools, along with the industry's leading suite of creative grading tools! The combination of URSA Mini and DaVinci Resolve gives you a complete production and post-production solution!

Blackmagic URSA Mini 4K



Blackmagic URSA Mini 4K EF

Compact and lightweight digital film camera with EF lens mount and 4K Super 35 sensor, 12G-SDI output, 5" fold out monitor, dual CFast recorders and more!



Blackmagic URSA Mini 4K PL

Compact and lightweight digital film camera with PL cinema lens mount and 4K Super 35 sensor, 12G-SDI output, 5" fold out monitor, dual CFast recorders and more!

Blackmagic URSA Mini 4.6K



Blackmagic URSA Mini 4.6K EF

Compact and lightweight digital film camera with high performance 4.6K Super 35 sensor with up to 15 stops of dynamic range,



Blackmagic URSA Mini 4.6K PL

Compact and lightweight digital film camera with high performance 4.6K Super 35 sensor with up to 15 stops of dynamic range,

EF lens mount, 12G-SDI, 5" fold out monitor, dual CFast recorders and more!

PL cinema lens mount, 12G-SDI, 5" fold out monitor, dual CFast recorders and more!

Blackmagic URSA Mini Accessories



Blackmagic URSA Mini B4 Mount

Change an URSA Mini PL lens mount to the broadcast industry's B4 lens mount so you can use existing high quality broadcast lenses for shooting in high definition.



Blackmagic URSA Viewfinder

High resolution viewfinder for URSA range of cameras includes full HD OLED display and true glass optics for perfect focus.



URSA PL Shim Set

Set of 8 shims for changing the flange focal distance for PL lenses with URSA PL.



URSA VLock Battery Plate

VLock compatible battery plate for attaching third party batteries to URSA cameras.



Blackmagic URSA Mini Shoulder Kit

Be ready to shoot anywhere! Kit includes shoulder pad with built in rosettes, rail mounts, integrated tripod quick lock release and top handle.