



For Surveillance Telephoto Zoom

Applicable camera (model)

H22x11.5R2D-ZP1

1	2/3	1/2	1/3	1/4
---	-----	-----	-----	-----

22x



*Photograph is a similar model.

- 22x telephoto zoom lens with near-infrared wavelength selection mechanism, best suited for day and night cameras.
- Achieved telephoto at the field angle of 1°27', best suited for long-distance monitoring such as disaster prevention (when used on 1/2" cameras).
- Equipped with the RS-232C interface for advanced control.
- Compatible with a wide range - 2/3", 1/2" and 1/3" - cameras.

ZOOM Zoom	WIDE Wide Angle	TELE Telephoto Long Focal	MOTOR DRIVE Motor Drive	Day~Night Day & Night	VIDEO Video Auto Iris	IRIS-REMOTE Iris Remote
C-mt C Mount	METAL Metal Mount	PC PC Control	SERVO Full Servo	ND ND Filter	F1.6 Wide Aperture Rate	RoHS RoHS Compliant

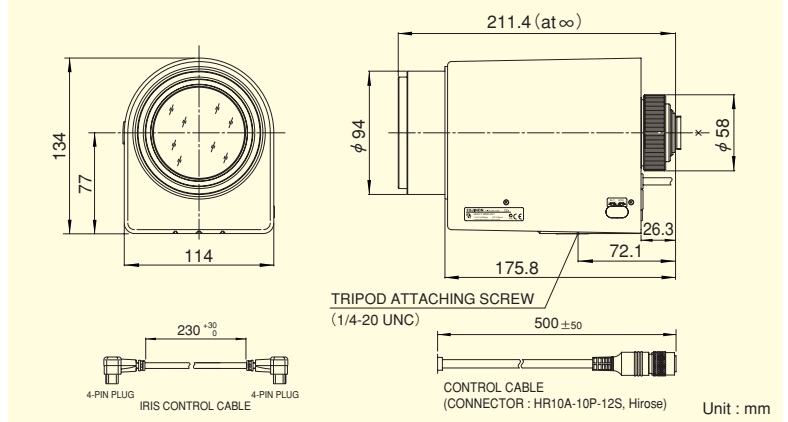

TELEPHOTO ZOOM LENSES

Focal Length (mm)		11.5~253 (22x)	
Iris Range		F1.6 ~ T2000 (Equivalent to F2000)	
Operation	Zoom	Servo Control	
	Focus	Servo Control	
	Iris	Auto (Video Type), Remote (*1) or Servo Control	
Angle Of View (H×V)	2/3"	WIDE	41°52' × 32°01'
		TELE	2°00' × 1°30'
	1/2"	WIDE	31°06' × 23°34'
		TELE	1°27' × 1°05'
	1/3"	WIDE	23°34' × 17°47'
		TELE	1°05' × 0°49'
Focusing Range (From Front Of The Lens) (m)		∞ ~ 3	
Object Dimensions at M.O.D. (H×V) (mm)	2/3"	WIDE	2213 × 1660
		TELE	101 × 75
	1/2"	WIDE	1609 × 1207
		TELE	73 × 55
	1/3"	WIDE	1207 × 905
		TELE	55 × 41
Back Focal Distance (in air) (mm)		36.16	
Exit Pupil Position (From Image Plane) (mm)		-103	
Filter Thread (mm)		M82 × 0.75	
Mount		C	
Mass (kg)		2.5	
Standard Accessories		Iris Control Cable Connection Connector (8-pin)	
Remarks		• With Metal Mount (*1) For Iris remote function please refer to page (H-1)	

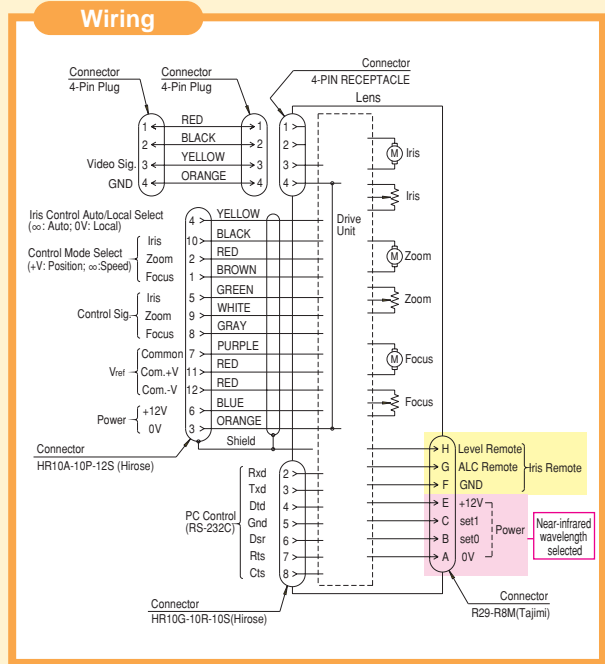

Near-infrared wavelength selected

		S0	S1
Near-infrared light	Visible light	OFF	OFF
	850nm	ON	OFF
	880nm	OFF	ON
	950nm	ON	ON

Accessories

■ Extender	
Model	Magnification
HE15-1	1.5X
HE20-1	2X