

JVC®

The Perfect Experience / —

1/3" CCD COLOUR VIDEO CAMERA

TK-C920BE

(24V AC/12V DC)

TK-C921BEG

(220V AC to 240V AC)

Revolutionary Camera with 550 TVL and Easy Day/Night Function

0.25 Super LoLux™
lx (in B&W Mode)

0.35 Super LoLux™
lx (in Colour Mode)



550 TV Lines Easy Day/Night

- 1/3" High Resolution IT CCD with 440,000 Effective Pixels
- 550 TV Lines of Horizontal Resolution
- Easy Day/Night Function: Chroma ON/OFF
- Super LoLux™ Sensitivity: 0.35 lx F1.2 in Colour Mode, 0.25 lx F1.2 in B&W Mode
- Signal-to-Noise Ratio: 50dB (AGC OFF)
- Focus Adjustment Function
- Display Mode CRT & LCD
- Integrated revolutionary 10-bit Digital Signal Processor (DSP)
- Automatic Electronic Shutter (AES) Mode ON/OFF
- Automatic Gain Control (AGC) ON/OFF
- Automatic Tracking White Balance (ATW) and Manual Modes
- Backlight Compensation ON/OFF
- Sync Systems INT/Line Lock
- Supports Video/DC Iris Lenses
- C/CS Lens Compatible
- Ultra Compact Camera Body
- 24V AC /12V DC Power Supply [TK-C920BE]
- 220V AC to 240V AC Power Supply [TK-C921BE]

Capture All The Important Details With JVC's 550 TVL CCD Advanced Surveillance Cameras!

These sophisticated colour surveillance cameras incorporate advanced features for enhanced identification capabilities even at night in low light conditions. From the moment you power a JVC camera, you experience true picture reproduction.

Easy Day/Night Function

The TK-C920BE and TK-C921BEG automatically use colour mode when the subject is bright, and B&W mode when it is dark. In B&W mode, AGC is always active to achieve high performance even in low light situations.

Focus Adjustment Function

When the focus adjustment function is turned ON, focusing is conducted with the lens iris fully open for about 30 seconds before returning to its original position. This results in a shallow depth of field (high-speed shutter) and simplifies focus adjustment.

Display Mode CRT & LCD

Images of the required brightness can be obtained by selecting the appropriate display mode both for a CRT monitor and LCD monitor.

Built-in Revolutionary Digital Signal Processor (DSP)

JVC's innovative Digital Signal Processor automatically adjusts camera parameters to ensure that sharp and natural pictures of 550 TV lines horizontal resolution combine with high-quality performance.

1/3" High Resolution IT CCD with 440,000 Effective Pixels

JVC's TK-C920BE and TK-C921BEG come with a 1/3" Interline Transfer CCD for accurate colour reproduction and signal-to-noise ratio of 50 dB.

Detail Corrections — Horizontal and Vertical (2H)

The TK-C920BE and TK-C921BEG provide dual-edged detail correction — horizontal and vertical with 2H line memory.

Super LoLux™ and Automatic Gain Control (AGC)

As the ambient light level falls the AGC seamlessly increases the camera's sensitivity. With Super LoLux™ turned on the AGC will further increase the camera's sensitivity to 0.35 lx at F1.2.

Manual or Automatic (ATW) White Balance

For flexibility of operation in a wide range of environments the white balance can be set manually or can be automatically adjusted in real time by the Automatic Tracking White Balance function over a range of 2,300K to 10,000K.

Dimensions

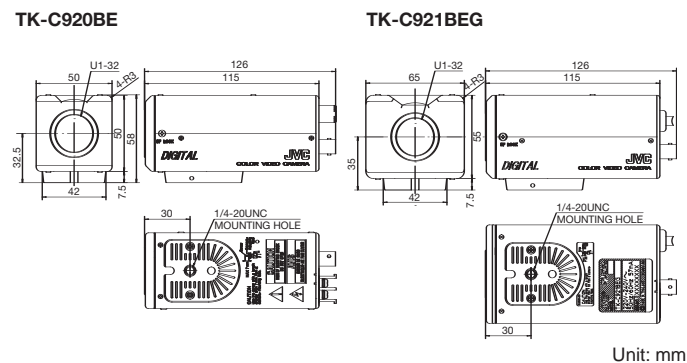

Unit: mm

Controls, connectors and indicators

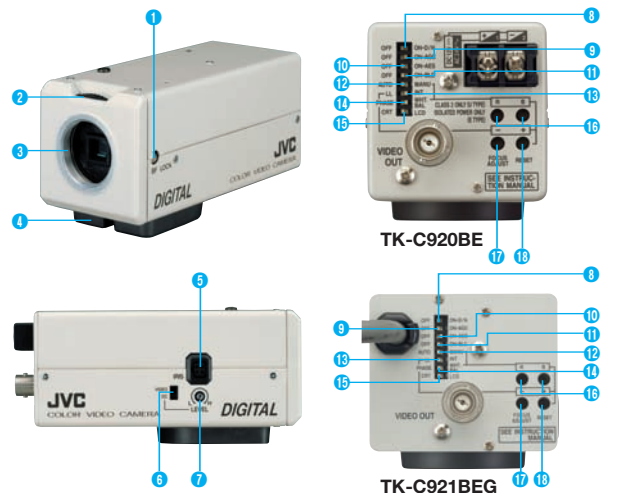

- 1 BACK FOCUS locking screw
- 2 BACK FOCUS adjustment and C/CS mount selector ring
- 3 Lens mount (C/CS)
- 4 Camera mounting bracket
- 5 IRIS connector
- 6 VIDEO/DC IRIS select switch
- 7 Iris level adjust
- 8 D/N (Easy Day/Night) ON/OFF
- 9 AGC (Automatic Gain Control) ON/OFF
- 10 AES (Automatic Electronic Shutter) ON/OFF
- 11 BLC (Backlight Compensation) ON/OFF
- 12 WHITE BALANCE select switch
- 13 LL/INT select switch
- 14 PHASE/W.B. select switch
- 15 Display mode select switch
- 16 PHASE/W.B. adjustment button
- 17 Focus adjustment button
- 18 RESET button

Specifications

Signal system	PAL
Image device	1/3" Interline transfer CCD
Number of effective pixels	440,000 (752 H x 582 V)
Pickup area	4.8 mm (H) x 3.6 mm (V)
Sync system	Internal, Line Lock
Scanning system	Interlace
Scanning frequency	15.625 kHz (H); 50 Hz (V)
Video output	Composite video signal: 1.0 V(p-p), 75 ohms (BNC)
Video S/N	50 dB (AGC off)
Horizontal resolution (typical)	550 TV lines
Minimum illumination (typical)	Colour mode: 0.35 lx (Video level 25%, F1.2, AGC on) 0.7 lx (Video level 50%, F1.2, AGC on) B&W mode: 0.25 lx (Video level 25%, F1.2, AGC on) 0.5 lx (Video level 50%, F1.2, AGC on)
Iris control	Video iris/DC iris
White balance	ATW/Manual (2,300K to 10,000K)
Display mode	CRT or LCD selectable
BLC	On/off
AES	On/off (1/50 to 1/100,000 sec.)
Focus adjustment	On/off
Lens mount	C/CS
Power supply	TK-C920BE: 24V AC (50Hz/60Hz), 12V DC TK-C921BEG: 220V AC to 240V AC (50 Hz/60 Hz)
Power consumption	TK-C920BE: 300 mA TK-C921BEG: 57 mA
Operating temperature range	-10°C to 50°C 0°C to 40°C (recommended)
Dimensions (W x H x D)	50 x 58 x 126 mm (TK-C920BE) 65 x 63 x 126 mm (TK-C921BEG)
Regulatory standard	EN60950
Weight	TK-C920BE: 370 g TK-C921BEG: 710 g

Design and specifications subject to change without notice.

JVC®

DISTRIBUTED BY



■ The Hachioji Plant of Victor Company of Japan, Ltd., has received ISO14001 and ISO9001 Certifications under the global standard for environmental management.