

S P E C F I L E

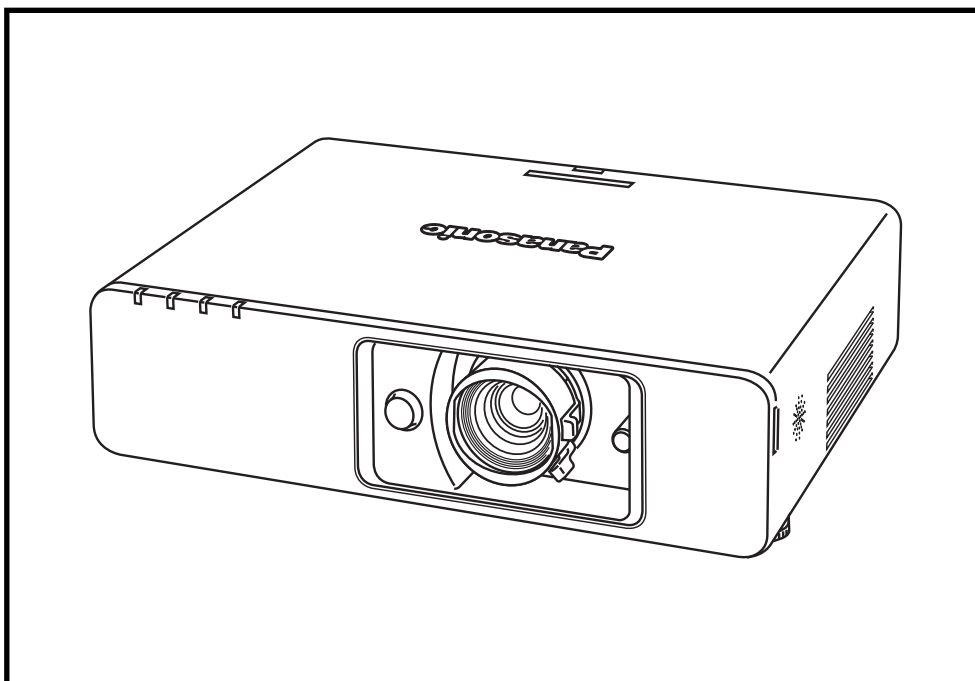

Product Number : **PT-FW300**

Product Name : LCD Projector

Specifications

Power supply		100–240 V AC, 50/60 Hz
Power consumption		350 W (Approx. 4 W in standby mode with fan stopped. Approx. 25 W when standby mode is turned on by a Web browser, and approx. 35 W when audio is output during standby mode.)
Optical system		Dichroic mirror separation/prism synthesis system
LCD panel	Panel size	0.75" (19.05 mm) diagonal, 16:10 aspect ratio
	Display method	Transparent LCD panel (x 3, R/G/B)
	Drive method	Active matrix
	Pixels	1,024,000 (1,280 x 800) x 3, total of 3,072,000 pixels
	Pixel configuration	Stripe
Lens		Manual zoom (1:1–1:2), manual focus F 1.7–2.6, f 21.6–43.0 mm
Lamp		250 W UHM lamp
Colors		Full color (16,777,216 colors)
Brightness*1		3,500 lumens
Center-to-corner uniformity*1		80%
Contrast ratio*1		600:1 (full on/full off)
Resolution	RGB	1,280 x 800 pixels (Input signals that exceed this resolution will be converted to 1,280 x 800 pixels.)
Scanning frequency	RGB YPbPr	Horizontal: 15.00–91.00 kHz, Vertical: 50–85 Hz 480i (525i): fH 15.75 kHz; fV 60 Hz 576i (625i): fH 15.63 kHz; fV 50 Hz 480p (525p): fH 31.50 kHz; fV 60 Hz 576p (625p): fH 31.25 kHz; fV 50 Hz 720 (750)/60p: fH 45.00 kHz; fV 60 Hz 720 (750)/50p: fH 37.50 kHz; fV 50 Hz 1080 (1125)/60: fH 33.75 kHz; fV 60 Hz 1080 (1125)/50i: fH 28.13 kHz; fV 50 Hz 1080 (1125)/60p: fH 67.50 kHz; fV 60 Hz 1080 (1125)/50p: fH 56.30 kHz; fV 50 Hz
	S-Video/Video	NTSC, NTSC4.43, PAL-M, PAL60: fH 15.75 kHz; fV 60 Hz PAL, SECAM, PAL-N: fH 15.63 kHz; fV 50 Hz
Projection size		838–7,620 mm (33–300 inches) diagonally, 16:10 aspect ratio
Throw distance		1.1 m–17.2 m (3'7"–56'5"), 16:10 aspect ratio
Optical axis shift		Vertical: ±51%, horizontal: ±24%
Keystone correction range		Vertical: approx. ±30°
Installation		Front/rear, ceiling/desk (menu selection)
On-screen menu		17 languages: English, French, German, Spanish, Italian, Korean, Russian, Chinese, Japanese, Swedish, Norwegian, Danish, Portuguese, Polish, Hungarian, Czech, and Thai
Built-in speakers	Size	4 cm (round), x 1
	Output power	5.0 W (monaural)
Terminals	DVI-D IN	DVI-D 24-pin x 1, DVI 1.0 compliant, HDCP compatible, for single link only EDID1: 480p, 576p, 720/60p, 720/50p, 1080/60i, 1080/50i, 1080/60p, 1080/50p EDID2: Compatible with non-interlaced signals only, Effective resolution: VGA (640 x 480)–SXGA+ (1,400 x 1,050)
	COMPUTER (RGB) 1 IN	D-sub HD 15-pin (female) x 1
	R, G, B:	G: 0.7 Vp-p, 75 ohms, Sync on green: 1.0 Vp-p, 75 ohms, B, R: 0.7 Vp-p, 75 ohms, HD/SYNC, VD: TTL (positive/negative polarity compatible)
	Y, Pb, Pr:	Y: 1.0 Vp-p (including sync signal), 75 ohms, Pb, Pr: 0.7 Vp-p, 75 ohms
	COMPUTER (RGB) 2 IN/COMPUTER 1 OUT	D-sub HD 15-pin x 1 (female) (Input/output is selected from the menu. When output is selected, the COMPUTER (RGB) 1 IN signal is output.)
	R, G, B:	G: 0.7 Vp-p, 75 ohms, Sync on green: 1.0 Vp-p, 75 ohms, B, R: 0.7 Vp-p, 75 ohms, HD/SYNC, VD: TTL (positive/negative polarity compatible)
	Y, Pb, Pr:	Y: 1.0 Vp-p (including sync signal), 75 ohms, Pb, Pr: 0.7 Vp-p, 75 ohms

	VIDEO IN	RCA pin x 1, 1.0 Vp-p, 75 ohms
	S-VIDEO IN	Mini DIN 4-pin x 1, Y: 1.0 Vp-p, C: 0.286 Vp-p, 75 ohms
	COMPUTER AUDIO IN 1	M3 (stereo) x 1, 0.5 Vrms, for COMPUTER 1
	COMPUTER AUDIO IN 2	M3 (stereo) x 1, 0.5 Vrms, for DVI-D and COMPUTER 2
	AUDIO IN	RCA (L, R) x 1, 0.5 V [rms], for VIDEO and S-VIDEO (default) (This can be switched by a setting for use as an audio input terminal for DVI-D/COMPUTER 1/COMPUTER 2.)
	VARIABLE AUDIO OUT	M3 (stereo) x 1, 0–2.0 Vrms (variable)
	SERIAL	D-sub 9-pin x 1, for external control (RS-232C)
	REMOTE	D-sub 9-pin x 1, for external control (contact control)
	LAN	RJ-45 x 1, compatible with PLink™ (class 1), 10BASE-T/100BASE-TX 2 m/6'7"
Power cord length		
Cabinet material		Moulded plastic (PC+ABS)
Dimensions (W x H x D)		432 x 128.5 x 323 mm (17" x 5-1/16" x 12-23/32")
Weight* ²		Approx. 6.2 kg (13.7 lbs.)
Operating environment	Temperature	0°–40°C (32°–104°F)
	Humidity	20%–80% (no condensation)
Remote control unit	Power supply	3 V DC (AA battery x 2)
	Operation range* ³	Approx. 15 m (49'3") when operated from directly in front of the signal receptor
	Dimensions (W x H x D)	48 x 163 x 24.5 mm (1-7/8" x 6-13/32" x 31/32")
	Weight	117 g (4.1 oz) (including batteries)
Wireless Manager ME 5.5 system requirements		To use network functions, a PC is required that meets the conditions given below.
	OS	Microsoft® Windows® 2000 Professional SP4, Windows® XP Professional, Windows® XP Home Edition, Windows® XP Tablet PC Edition 2005, Windows Vista® Ultimate 32-bit, Windows Vista® Business 32-bit, Windows Vista® Home Premium 32-bit, Windows Vista® Home Basic 32-bit Apple Mac OS X 10.4 (Tiger) and OS X 10.5 (Leopard) NOTE: Some functions are not available with Windows Vista® and Mac.
	Web browser	Windows®: Internet Explorer 6.0 or later, or Netscape Communicator 7.0 or later Macintosh: Safari 2.0 or later
	CPU	Windows®: Intel® Pentium® III or higher, or other compatible processor (1 GHz or higher is recommended.) Macintosh: 1.0-GHz or higher PowerPC G4, or 1.8-GHz or higher Intel® Core™ processor
	Memory	256 MB or more (512 MB or more is recommended for Macintosh.)
	Free hard disk space	60 MB or more
	CD-ROM drive	CD-ROM drive or DVD drive
	Wired LAN connector	RJ-45
Supplied accessories		Power cord (x 1) Power cord secure lock (x 1) Wireless remote control (x 1) Batteries for remote control (AA battery x 2) Wireless Manager ME 5.5 (CD-ROM) (x 1) Safety wire rope (x 1)
Optional accessories		Replacement lamp unit: ET-LAF100 Replacement filter unit: ET-ACF100 Ceiling mount bracket for high ceilings: ET-PKF100H Ceiling mount bracket for low ceilings: ET-PKF100S

*1 Measurement, measuring conditions, and method of notation all comply with ISO 21118 international standards.

*2 Operation range differs depending on environments.

*3 Average value. May differ depending on models.

Weights and dimensions shown are approximate. Specifications are subject to change without notice. Product availability differs depending on region and country. This product may be subject to export control regulations. Intel, Pentium, and Intel Core are trademarks or registered trademarks of Intel Corporation or its subsidiaries in the United States and other countries. Microsoft, Windows Vista and Windows are either registered trademarks or trademarks of Microsoft Corp. in the United States and/or other countries. Apple, Mac, Mac OS, and Macintosh are trademarks of Apple Inc., registered in the U.S. and other countries. PowerPC is a trademark of International Business Machines Corporation, registered in the U.S. PLink is a registered trademark or trademark in Japan, the United States, and other countries and regions. All other trademarks are the property of their respective trademark owners.

Dimensions

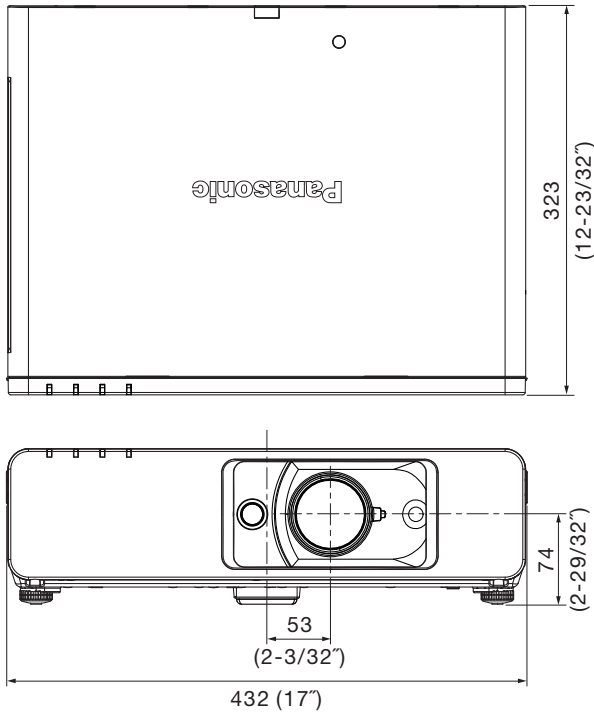

unit : mm (inch)
NOTE: This illustration is not drawn to scale.

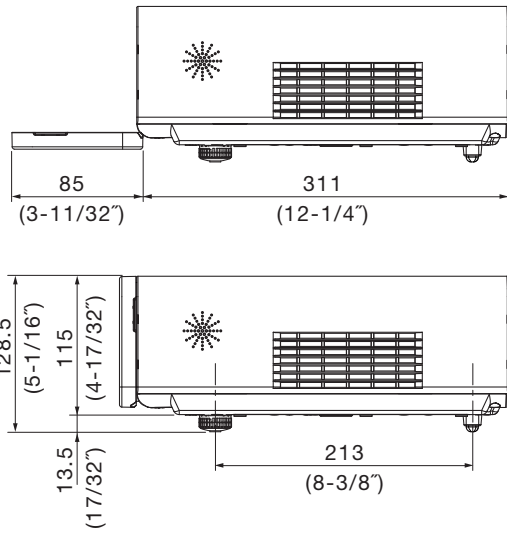

Terminals

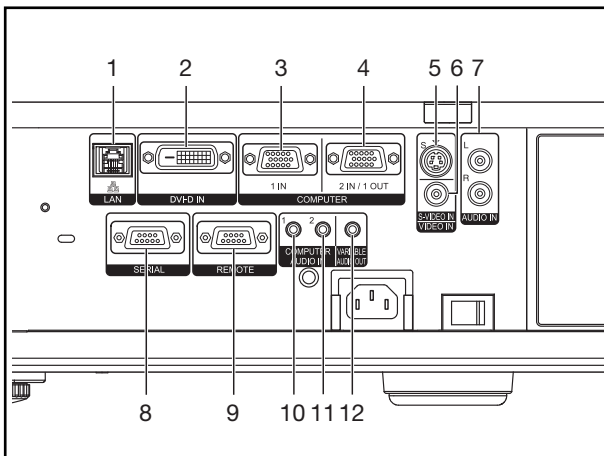

- 1 LAN
- 2 DVI-D input
- 3 Computer 1 input
- 4 Computer 2 input/computer 1 output
- 5 S-Video input
- 6 Video input
- 7 Audio input for S-Video and video
- 8 Serial input
- 9 Remote input
- 10 Audio input for computer 1
- 11 Audio input for DVI-D and computer 2
- 12 Audio output

Standard setting-up positions

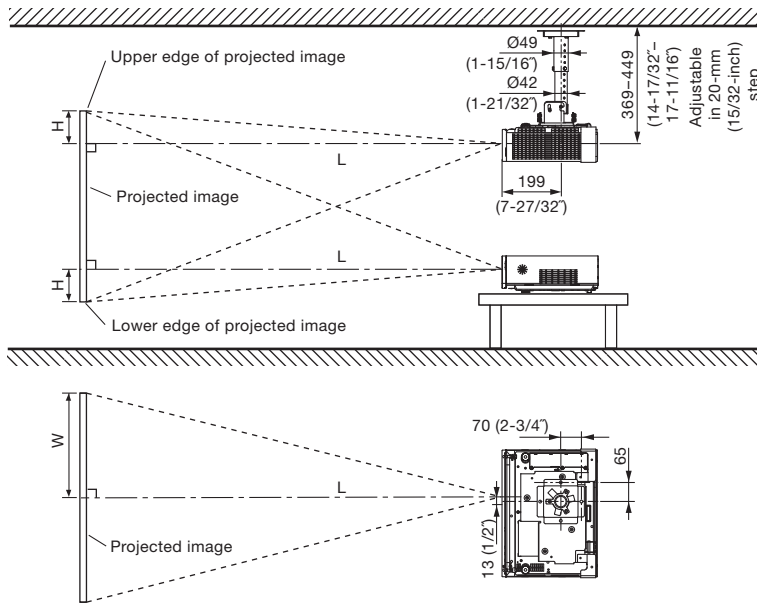

unit : mm (inch)

L: Distance to screen
H: Height from the edge of screen to center of lens

NOTE:
Illustrations show the projector installed using optional ceiling bracket.
This illustration is not drawn to scale.

Projection distance (screen aspect ratio 16:10)

Projection size (diagonal)	Projection distance (L)		Height from the edge of screen to center of lens (H)
	Min (wide)	Max (telephoto)	
0.84 m / 33"	- / -	1.8 m / 6.0'	0 - 0.23 m / 0 - 0.7'
1.02 m / 40"	1.1 m / 3.6'	2.3 m / 7.4'	0 - 0.28 m / 0 - 0.9'
1.27 m / 50"	1.4 m / 4.6'	2.8 m / 9.2'	0 - 0.35 m / 0 - 1.1'
1.52 m / 60"	1.7 m / 5.5'	3.4 m / 11.1'	0 - 0.42 m / 0 - 1.4'
1.78 m / 70"	2.0 m / 6.5'	4.0 m / 13.0'	0 - 0.49 m / 0 - 1.6'
2.03 m / 80"	2.3 m / 7.4'	4.6 m / 14.9'	0 - 0.55 m / 0 - 1.8'
2.29 m / 90"	2.6 m / 8.4'	5.1 m / 16.8'	0 - 0.62 m / 0 - 2.0'
2.54 m / 100"	2.9 m / 9.3'	5.7 m / 18.7'	0 - 0.69 m / 0 - 2.3'
3.05 m / 120"	3.4 m / 11.2'	6.9 m / 22.5'	0 - 0.83 m / 0 - 2.7'
3.81 m / 150"	4.3 m / 14.1'	8.6 m / 28.1'	0 - 1.04 m / 0 - 3.4'
5.08 m / 200"	5.7 m / 18.8'	11.5 m / 37.6'	0 - 1.39 m / 0 - 4.5'
6.35 m / 250"	7.2 m / 23.6'	14.3 m / 47.0'	0 - 1.73 m / 0 - 5.6'
7.62 m / 300"	8.6 m / 28.3'	17.2 m / 56.5'	0 - 2.08 m / 0 - 6.8'

* This distance is especially recommended for ceiling-mounted use and other permanent installations.

NOTE:
Values shown are approximate. The value for L (distance to screen) varies slightly depending on the zoom lens characteristics.
When the shortest projection distance is used, a small amount of distortion may occur in the image due to the zoom lens characteristics.
The value for H (the height from the edge of the screen to the centre of the lens) is the value when the horizontal optical axis shift function is not used. The value decreases when the horizontal optical axis shift function is used. For details, see Shift range on page 7.

Projection distance (screen aspect ratio 16:9)

Projection size (diagonal)	Projection distance (L)		Height from the edge of screen to center of lens (H)
	Min (wide)	Max (telephoto)	
0.84 m / 33"	- / -	1.9 m / 6.2'	0 - 0.24 m / 0 - 0.8'
1.02 m / 40"	1.2 m / 3.8'	2.3 m / 7.6'	0 - 0.29 m / 0 - 0.9'
1.27 m / 50"	1.4 m / 4.7'	2.9 m / 9.5'	0 - 0.36 m / 0 - 1.2'
1.52 m / 60"	1.7 m / 5.7'	3.5 m / 11.5'	0 - 0.43 m / 0 - 1.4'
1.78 m / 70"	2.0 m / 6.7'	4.1 m / 13.4'	0 - 0.5 m / 0 - 1.6'
2.03 m / 80"	2.3 m / 7.6'	4.7 m / 15.3'	0 - 0.57 m / 0 - 1.9'
2.29 m / 90"	2.6 m / 8.6'	5.3 m / 17.3'	0 - 0.64 m / 0 - 2.1'
2.54 m / 100"	2.9 m / 9.6'	5.9 m / 19.2'	0 - 0.71 m / 0 - 2.3'
3.05 m / 120"	3.5 m / 11.5'	7.1 m / 23.1'	0 - 0.86 m / 0 - 2.8'
3.81 m / 150"	4.4 m / 14.5'	8.8 m / 28.9'	0 - 1.07 m / 0 - 3.5'
5.08 m / 200"	5.9 m / 19.3'	11.8 m / 38.6'	0 - 1.43 m / 0 - 4.7'
6.35 m / 250"	7.4 m / 24.2'	14.7 m / 48.4'	0 - 1.78 m / 0 - 5.8'
7.62 m / 300"	8.9 m / 29.1'	17.7 m / 58.1'	0 - 2.14 m / 0 - 7.0'

Calculation of the projection distance

For a screen size different from the above, use the equation below to calculate the projection distance.

Aspect ratio 16 : 10

minimum $L (m) = (\text{diagonal screen size in inches}) \times 0.0289 - 0.046$

maximum $L (m) = (\text{diagonal screen size in inches}) \times 0.0576 - 0.061$

Aspect ratio 16 : 9

minimum $L (m) = (\text{diagonal screen size in inches}) \times 0.0297 - 0.045$

maximum $L (m) = (\text{diagonal screen size in inches}) \times 0.0592 - 0.061$

NOTE:

Distances calculated with the above equations will include a slight error.

Shift range

Optical axis shift function allows to shift the position of a projected image as shown below.

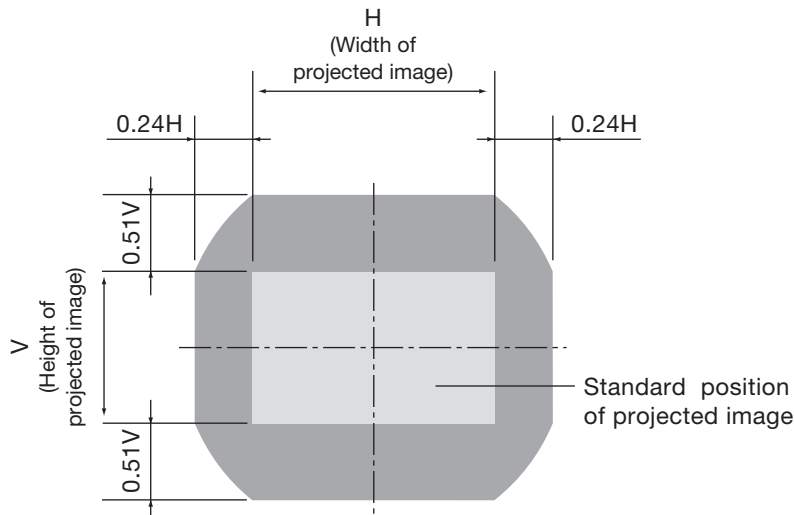

Installable angle

Install the projector at an angle within the range shown below..

• Vertical direction

The projector may be installed at a vertical angle of $\pm 30^\circ$.

• Horizontal direction

The projector may not be angled horizontally.

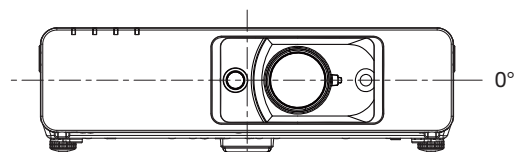
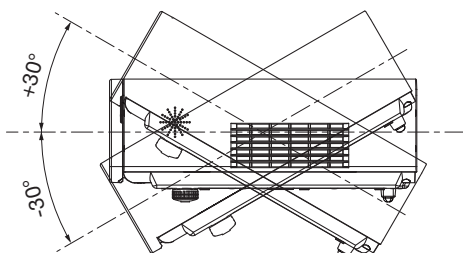

Computer data compatibility

This projector accepts up to 91 kHz horizontal scanning frequency and 162 MHz dot clock.

NOTE: Pixel thinning is applied to signals that exceed a dot clock frequency of 150 MHz. The display resolution of this projector is 1,280 x 800 pixels. If the display resolution indicated in the above data exceeds this resolution, image compression will be used to convert the input signal to 1,280 x 800 pixels.

List of compatible signals

Display mode	Display resolution (dots) ¹	Scanning frequency H (kHz)	V (kHz)	Dot clock frequency (MHz)	Picture quality ²	Format	Plug and Play compatibility RGB 2 input	DVI-D input EDID1	EDID2
NTSC/NTSC4.43/PAL-M/PAL60	720 x 480i	15.7	59.9	–	A	VIDEO/S-VIDEO	No	No	No
PAL/PAL-N/SECAM	720 x 576i	15.6	50.0	–	A				
525i(480i)	720 x 480i	15.7	59.9	13.5	A	COMPUTER/YPbPr	No	No	No
625i(576i)	720 x 576i	15.6	50.0	13.5	A				
525p(480p)	720 x 483	31.5	59.9	27.0	A	DVI/COMPUTER/YPbPr	No	Yes	No
625p(576p)	720 x 576	31.3	50.0	27.0	A				
750(720)/60p	1,280 x 720	45.0	60.0	74.3	A				
750(720)/50p		37.5	50.0	74.3	A				
1125(1080)/60i	1,920 x 1,080i	33.8	60.0	74.3	A				
1125(1080)/50i		28.1	50.0	74.3	A				
1125(1080)/60p	1,920 x 1,080	67.5	60.0	148.5	A				
1125(1080)/50p		56.3	50.0	148.5	A				
1125(1080)/60p		66.6	59.9	138.5	A	COMPUTER	No	No	No
1125(1080)/50p		55.6	49.9	141.5	A				
VESA	640 x 400	31.5	70.1	25.2	A				
		37.9	85.1	31.5	A				
VGA	640 x 480	31.5	59.9	25.2	A	DVI/COMPUTER	Yes	No	Yes
		35.0	66.7	30.2	A	COMPUTER	Yes	No	No
		37.9	72.8	31.5	A				
		37.5	75.0	31.5	A				
		43.3	85.0	36.0	A		No	No	No
SVGA	800 x 600	35.2	56.3	36.0	A		Yes	No	No
		37.9	60.3	40.0	A	DVI/COMPUTER	Yes	No	Yes
		48.1	72.2	50.0	A	COMPUTER	Yes	No	No
		46.9	75.0	49.5	A				
		53.7	85.1	56.3	A		No	No	No
MAC	832 x 624	49.7	74.6	57.3	A		Yes	No	No
XGA	1,024 x 768	39.6	50.1	51.9	A	DVI/COMPUTER	No	No	No
		48.4	60.0	65.0	A		Yes	No	Yes
		56.5	70.1	75.0	A				
		60.0	75.0	78.8	A				
		68.7	85.0	94.5	A		No	No	No
WIDE750(720)	1,280 x 720	44.8	59.9	74.5	A	COMPUTER	Yes	No	No
		37.1	49.8	60.5	A		No	No	No
WXGA768	1,280 x 768	39.6	49.9	65.3	AA	DVI/COMPUTER			
		47.8	59.9	79.5	AA		Yes	No	Yes
WXGA800	1,280 x 800	41.3	50.0	68.0	AA		No	No	No
		49.1	60.2	69.1	AA	COMPUTER			
		49.7	59.8	83.5	AA	DVI/COMPUTER	Yes	No	Yes
MXGA	1,152 x 864	64.0	71.2	94.2	A	COMPUTER	Yes	No	No
		67.5	74.9	108.0	A		No	No	No
		76.7	85.0	121.5	A				
MAC	1,152 x 870	68.7	75.1	100.0	A		Yes	No	No
MSXGA	1,280 x 960	60.0	60.0	108.0	A				
SXGA	1,280 x 1,024	64.0	60.0	108.0	A	DVI/COMPUTER	No	No	Yes
		80.0	75.0	135.0	A	COMPUTER	Yes	No	No
		91.1	85.0	157.5	B		No	No	No
SXGA60+	1,400 x 1,050	64.0	60.0	108.0	A				
		65.1	59.9	122.4	A	DVI/COMPUTER	Yes	No	Yes
WXGA+	1,440 x 900	55.9	59.9	106.5	A	COMPUTER	Yes	No	No
UXGA	1,600 x 1,200	75.0	60.0	162.0	B				
WSXGA+	1,680 x 1,050	65.3	60.0	146.3	A				
WUXGA	1,920 x 1,200	74.6	59.9	154.0	B		No	No	No

1. The "i" appearing after the resolution indicates an interlaced signal.

2. The following symbols are used to indicate picture quality.

AA: Maximum picture quality can be obtained. A: Signals are converted by the image processing circuit before picture is projected.

B: Pixels are thinned by the image processing circuit before picture is projected.

Serial connector

The serial connector complies with RS-232C. To control the projector from a personal computer, commands must be input through communication software, based on the format and satisfying the communication conditions shown below.

Pin assignments and signal names

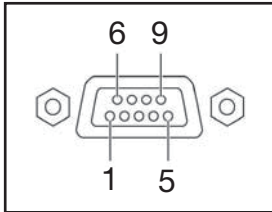

D-sub HD 9-pin, female

No.	Signal name	Description	No.	Signal name	Signal name
1	-	NC	6	-	NC
2	TXD	Send data	7	RTS	Connected internally
3	RXD	Receive data	8	CTS	Connected internally
4	-	Connected internally	9	-	NC
5	GND	Ground			

* Effective when connected to a PC having proper functions.

Communication conditions (factory setting)

Signal level	RS-232C-compliant
Synchronization method	Start-stop synchronization
Baud rate	9,600 bps
Parity	None
Character length	8 bits
Stop bit	1 bit
X parameter	None
S parameter	None

Basic format

Transmission from the computer begins with STX, then the ID, command, parameter, and ETX are sent in this order. Add parameters according to the details of control.

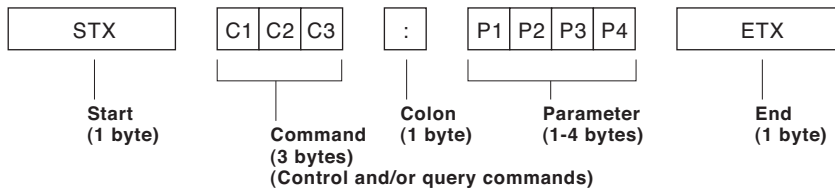

CAUTION

It may not be possible to send or receive commands for about 10 to 60 seconds when the lamp is first turned on. If this occurs, wait for 60 seconds, then try sending or receiving again. When sending multiple commands, be sure to wait for at least 0.5 second after receiving a response from the projector before sending the next command. Additional time is sometimes required for response due to processing inside the projector. Set the time-out period for command response to 10 seconds or more.

NOTE:

If a wrong command is received, the projector will send an ER401 command to the computer. When sending commands without parameters, a colon (:) is not necessary.

Cable specifications

Projector		PC (DTE)	
1	NC	NC	1
2			2
3			3
4	NC	NC	4
5			5
6	DSR	NC	6
7			7
8			8
9	NC	NC	9

Control commands

Command: <Parameter>	Function	Callback: <Parameter>	Parameter value	
			Min	Max
PON ^{*1}	Power on (standby mode on)	PON	-	-
POF ^{*1}	Power off (standby mode off)	POF	-	-
AVL:<p1>	Volume control	AVL:<p1>	0	63
IIS:<input signal>	Input signal selection	IIS:<input signal>	-	-
OST	The same function as "default" button	OST	-	-
OFZ:<off on>	Freeze	OFZ:<off on>	0	1
OEN	Enter	OEN	-	-
OXG: 0	Wide mode: Off	OXG: 0	-	-
OXG: 1	Wide mode: On	OXG: 1	-	-
OXG: 2	Wide mode: Auto	OXG: 2	-	-
VPM:<NAT>	Picture mode: Natural	VPM:<NAT>	-	-
VPM:<STD>	Picture mode: Standard	VPM:<STD>	-	-
VPM:<CIN>	Picture mode: Cinema	VPM:<CIN>	-	-
VPM:<DYN>	Picture mode: Dynamic	VPM:<DYN>	-	-
VPM:<BBD>	Picture mode: Blackboard	VPM:<BBD>	-	-
VXX:DLVI0=<+00000>	Daylight View: Off	VXX:DLVI0=<+00000>	-	-
VXX:DLVI0=<+00001>	Daylight View: Auto	VXX:DLVI0=<+00001>	-	-
VXX:DLVI0=<+00002>	Daylight View: On	VXX:DLVI0=<+00002>	-	-
AUU	Volume up	AUU	--	-
AUD	Volume down	AUD	--	-
OMN	Menu	OMN	-	-
OCU	Cursor up	OCU	-	-
OCD	Cursor down	OCD	-	-
OCL	Cursor left	OCL	-	-
OCR	Cursor right	OCR	-	-
OAS	Auto setup	OAS	-	-
OSH ^{**1/2}	Shutter	OSH	-	-
OIX	Index window	OIX	-	-
DZU	Digital zoom: Enlargement	DZU	-	-
DZD	Digital zoom: Reduction	DZD	-	-
TSD:<date>	Date setting	TSD:<date>	-	-
TST:<time>	Time setting	TST:<time>	-	-

*1 Do not send PON, POF, or OSH commands continuously in a short period of time. Doing so may burst the lamp or shorten the lamp replacement cycle.
 *2 When a command other than OSH is sent while the shutter function is operating, the projector will send an ER401 command in reply and release the shutter function.

Status asking commands

Command	Description	Callback <Parameter>
QPW	Standby power status	<power condition>
QSS	Lamp status	<lamp condition>
QIN	Input signal status	<input signal>
QAV	Volume adjustment value	<p1>
QVC	Color adjustment value	<p1>
QVT	Tint adjustent value	<p1>
QVB	Brightness adjustment value	<p1>
QVR	Contrast adjustment value	<p1>
QVS	Sharpness adjustment value	<p1>
QWR	White balance: R adjustment value	<p1>
QWG	White balance: G adjustment value	<p1>
QWB	White balance: B adjustment value	<p1>
QHP	Horizontal position adjustment value	<p1>
QVP	Vertical position adjustment value	<p1>
QCP	Clock phase adjustment value	<p1>
QDC	Dot clock adjustment value	<p1>
QSP	Projection method status	<p1>
QLG	On-screen menu language	<p1>
QXG	Wide mode status	Off <0> On <1> Auto <0>
QVX:DLVI0	Daylight View status	Off <+00000> Auto <+00001> On <+00002>
QPM	Picture mode status	Natural <NAT> Standard <STD> Cinema <CIN> Dynamic <DYN> Blackboard <BBD>
QFZ	Freeze status	<off on>
QSL	Lamp run time	<acctch>
QSH	Shutter function status	<off on>
QKS	Keystone correction status	<p1>
QTE	Color temperature adjustment status	<color temp>
QGD	Date setting status	<date>
QGT	Time setting status	<time>

Parameter format

Parameter format	Size (Byte)	Definition
<pl>	3 (1 or 2 bytes also possible when under control)	Decimal without signs: 0-999 (000, 001, 002...999) Decimal with signs: -99 to +99 (-99...-01, +00, +01, +02...+99) Callback from the projector is 3 Byte.
<off on>	1	0 = off, 1 = on
<input signal>	3	DVI = DVI-D, RG1 = computer 1, RG2 = computer 2, NWP = network, VID = video, SVD = S-Video
<installation>	1	0 = front, 1 = rear, 2 = ceiling and front, 3 = ceiling and rear
<language>	3	ENG = English, DEU = German, FRA = French, ESP = Spanish, ITL = Italian, JPN = Japanese, CHI = Chinese, POR = Portuguese, SVE = Swedish, NOR = Norwegian, DAN = Danish, POL = Polish, CES = Czech, MAG = Hungarian, RUS = Russian, THA = Thai, KOR = Korean
<power condition>	3	000 = power on (standby mode on), 001 = power off (standby mode off)
<lamp condition>	1	0 = standby, 1 = lamp on under control, 2 = lamp off, 3 = lamp off under control
<acctch>	4	Dicimal without signs: 0000-9999 hours
<color temp>	1	0 = low, 1 = default, 2 = high
<date>	8	y1y2y3y4m1m2d1d2w = year (y) month (m) day (d) day of week (w) Day of week: Monday = 1, Tuesday = 2, ... Sunday = 7
<time>	6	h1h2m1m2s1s2 = hour (h) minute (m) second (s)

NOTE: If a wrong command is received, the projector will send an ER401 command to the computer.

Command example

To set the volume to +30, send the command as shown below.



NOTE: When sending commands without parameters, a colon (:) is not necessary.

Notes on Projector Placement and Operation

The projector uses a high-wattage lamp that becomes very hot during operation. Please observe the following precautions.

1. Never place objects on top of the projector while it is operating.
2. Make sure there is an unobstructed space of 500 mm (19-11/16") or more around the projector's exhaust openings. In addition to this space, also ensure that there is a sufficient work space for removing and installing the lamp, filter and other parts.
3. If the projector is placed in a box or enclosure, ensure the temperature of the air surrounding the projector is between 0°C/32°F and 35°C/95°F. Also make sure the projector's intake and exhaust openings are not blocked. Take particular care to ensure that hot air from the exhaust openings is not sucked into the intake openings.

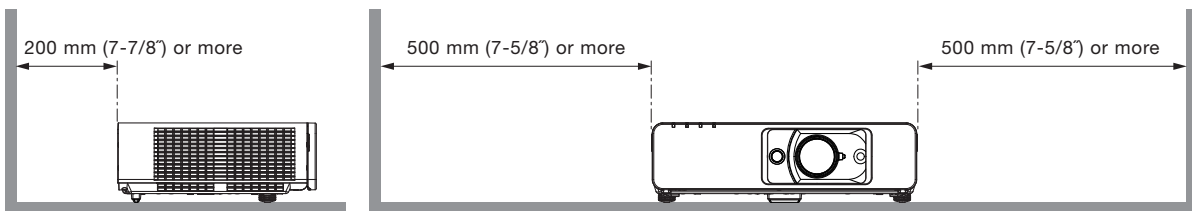

Direction of Air Intake and Exhaust

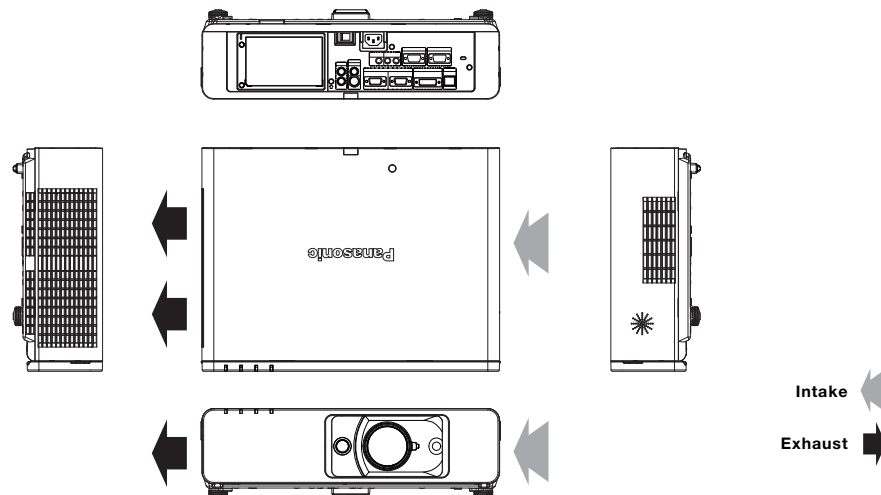

Operating the Projector Continuously

1. When the projector is operated continuously 10 hours or more, the lamp replacement cycle decreases.
2. The lamp replacement cycle also decreases when the projector is used for short periods of time (less than one hour) repeatedly.

Replacing the Filter Unit

The projector is equipped with the Auto Cleaning Filter (ACF) function, which automatically winds the air filter to set a new filter element in place according to operating conditions. The filter unit replacement cycle is approximately 10,000 hours. Please purchase the ET-ACF100 filter unit for replacement use.

Weights and dimensions shown are approximate. Specifications are subject to change without notice. Product availability differs depending on region and country. This product may be subject to export control regulations. Intel, Pentium, and Intel Core are trademarks or registered trademarks of Intel Corporation or its subsidiaries in the United States and other countries. Microsoft, Windows Vista and Windows are either registered trademarks or trademarks of Microsoft Corp. in the United States and/or other countries. Apple, Mac, Mac OS, and Macintosh are trademarks of Apple Inc., registered in the U.S. and other countries. PowerPC is a trademark of International Business Machines Corporation, registered in the U.S. P.JLink is a registered trademark or trademark in Japan, the United States, and other countries and regions. All other trademarks are the property of their respective trademark owners.