

■Product summary

A touch panel compatible with a 50-inch plasma display, this device achieves the high resolution of Approx. 32 000 x 18 000 while maintaining an extremely thin and compact design.

With a built-in USB interface, the touch panel can be easily connected to peripheral devices of equipment such as personal computers.

■Product specifications (Design and specifications are subject to change without notice)

Spec	
Detection system	Infrared retroreflective detection
Panel aperture (W x H)	1128 mm (W) x 648 mm (H) (44.4" x 25.5")
Detection range (W x H)	1106 mm (W) x 622 mm (H) (43.5" x 24.5")
Effective detection range	1106 mm (W) x 622 mm (H) (43.5" x 24.5")
Operation modes	Input point, Continuous, End point detection
Resolution (W x H)	32 000 (W) x 18 000 (H) points *1
Output system	Coordinate output
Optical elements	Infrared LED 4 pcs, CMOS image sensor 2 pcs
Minimum detection size	8 mm (0.3")
Response rate	100 points / sec.
Interface Spec	
Interface	USB 2.0 full speed device
Compliant signal	+DATA, -DATA, VCC, GND
I/F Connector	TYPE B
Structure	
Panel shape	Flat panel
Dimensions (W x H x D)	1 206.4 mm (W) x 798.6 mm (H) x 47.9 mm (D) (47.5" X 31.4" x 1.9") (Except bracket, Inclusive of protruding portion)
Weight	4.6 kg (10.1 lbs) (Except bracket)
Escutcheon (frame)	Aluminum
Environment	
Temperature	Operation 0 to 40 °C (Temperature gradient) *2
Humidity	Operation 20 to 80 % (No dewing) *2
Resistance to external light	Lateral light 2 000 lx + 20 % (20° angle of incidence)
	Frontal light 10 000 lx + 20 % (90° angle of incidence)
Main unit	
Power supply (voltage)	DC + 5 V ± 10 % (Supplied from USB bus power)
Electric current	DC + 5 V max. 450 mA

*1 : Resolution obtained by using a dedicated driver software.

*2 : When the panel is attached to plasma display produced by Matsushita Electric Industrial Co., Ltd.

- Accessories
- USB Cable
 - CD-ROM
 - Operating instructions
 - Ferrit core
 - Tuch pen
 - Mounting bracket (A) (B)
 - Mounting bracket (B)
 - Vertical mounting bracket
 - USB cable anchor
 - Mounting screws (A) (B)
 - Tuch pen
 - Velcro strip
 - Rubber feet
 - USB driver touch panel setting program (aplicable OS : Microsoft, Windows 2000, Windows XP, Windows Vista (32 bit))

■ Dimensions

Cautions : This drawing is not a scale.

Unit : mm (inches)

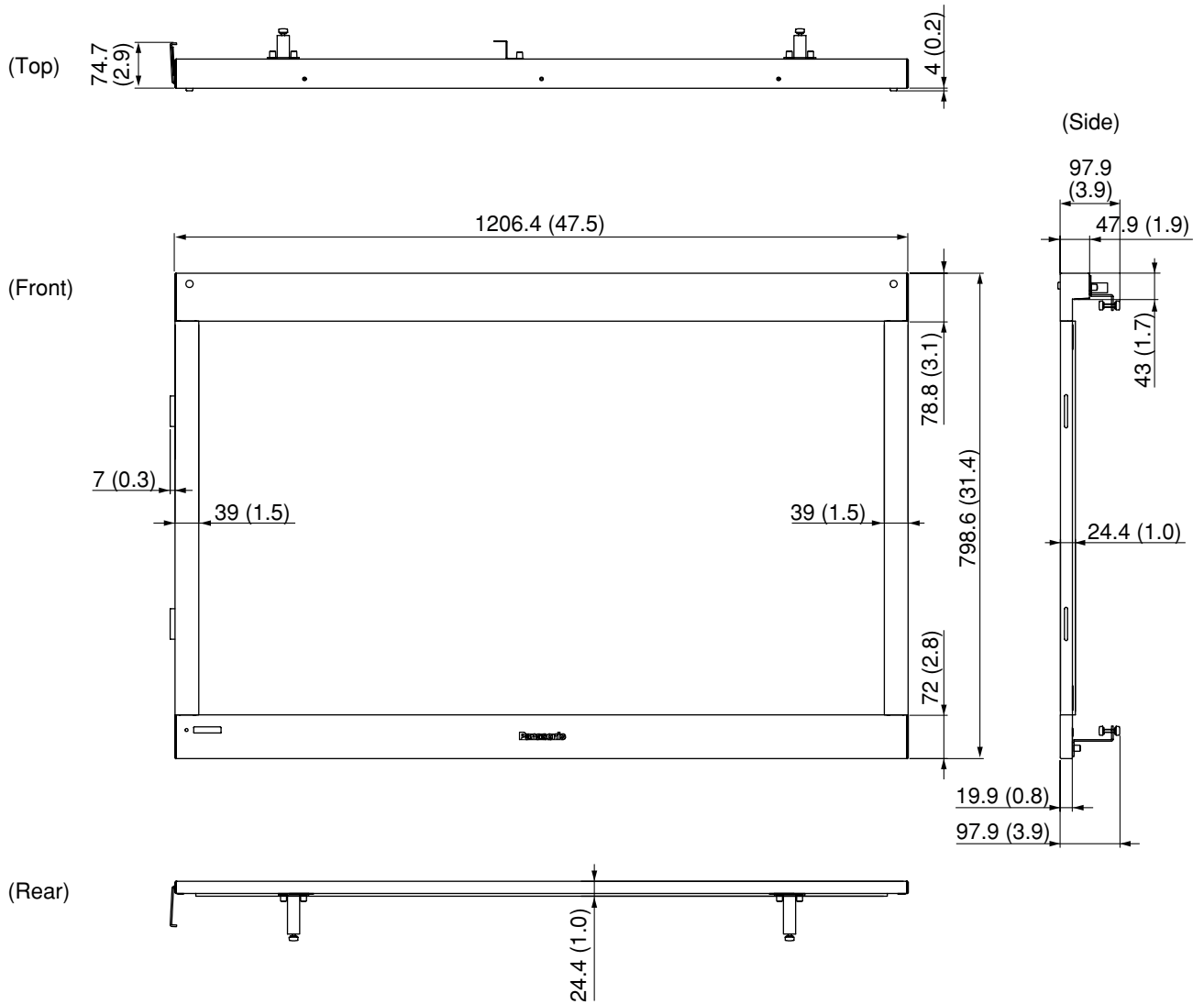

<When installed pedestal> (TY-ST07-K/S)

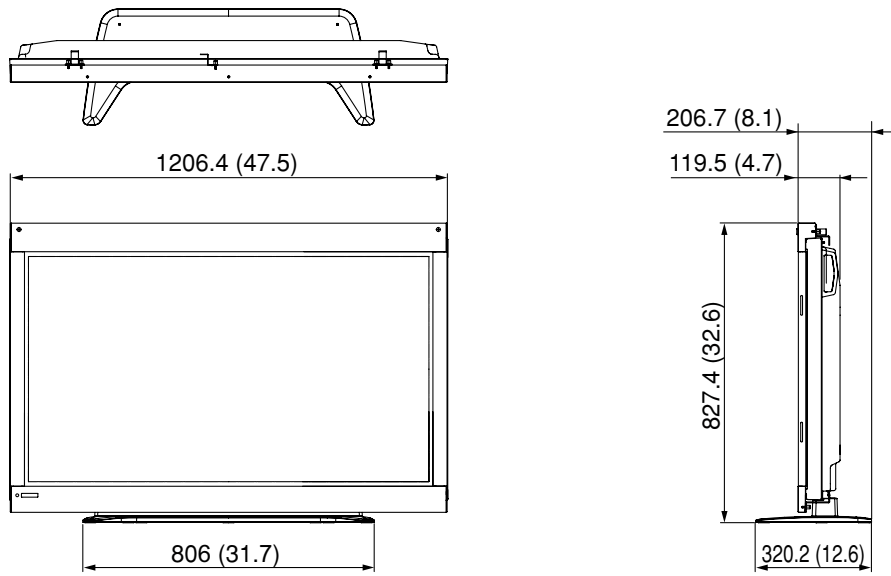

<When installed Mobile stand (with caster)> (TY-ST58PF10)

