

Panasonic

Wall Mount Bracket Instructions

Model Nos. WV-Q118/WV-Q118E

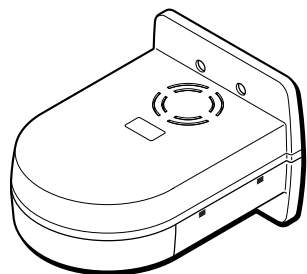

Before attempting to connect or install this product, please read these instructions carefully and save this manual for future use.

AM0205-0 3TR003444AAA Printed in Japan

FEATURES

The Wall Mount Bracket WV-Q118 is provided for mounting the Combination Camera WV-CS950 or WV-CS954 onto the wall.

PRECAUTIONS

- Fasten the bracket to a ceiling strong enough to support the camera weight (approx. 3 kg (6.60 lbs)).
 - Wipe the bracket regularly using a soft dry cloth, or a cloth moistened with a water solution of an ordinary kitchen detergent.
 - Do not use chemicals for cleaning the enclosure as it may damage the surface.
 - All the necessary steps required for installing this product must be taken by a qualified service person or system installer.
 - Be sure to use the Fall Prevention Wire.
 - Do not use this bracket with any equipment other than the WV-CS950 and the WV-CS954.
 - Follow all applicable local and national electrical, fire and safety codes when installing the camera with this ceiling mount bracket.
- The model numbers in this Operating Instructions are shown without suffix.

PLACES OF INSTALLATION

There are various ways of installing the camera as shown below.

● Wall Box

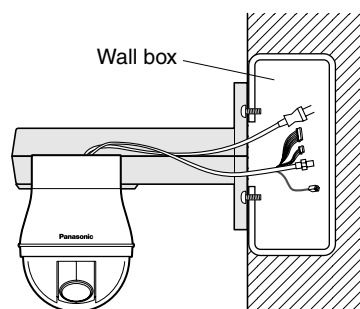

● Wood Siding Board

Wood Siding Board
Strong enough to support the camera weight (approx. 3 kg (6.60 lbs))

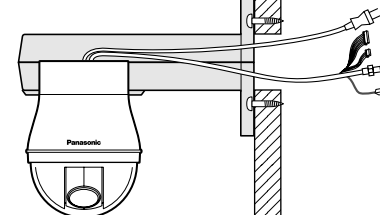

● Concrete

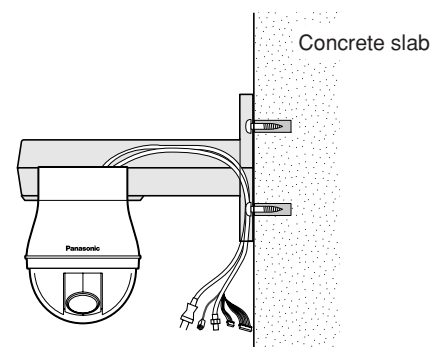
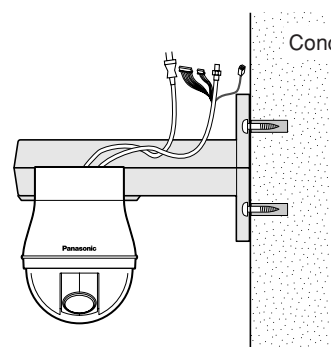

INSTALLATION

- 1 Make four holes in the wall using the template (provided).

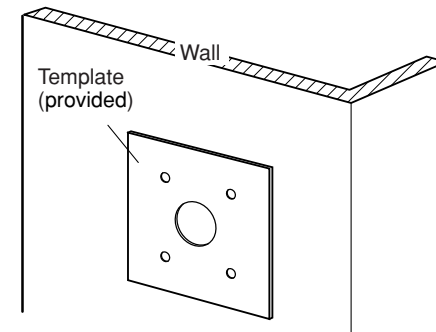

- 2 Wrap the camera cables with the Protection Cover (provided) as appropriate to the Diecast Case.

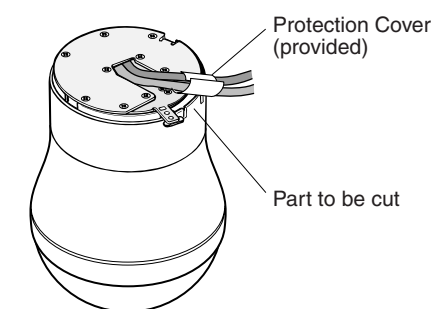

- 3 Remove the Mounting Screw (M3, provided), pull up the Camera Mounting Base off the camera, and turn the camera counterclockwise.

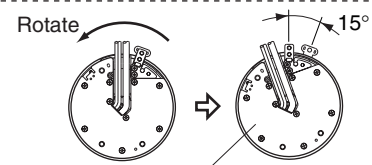
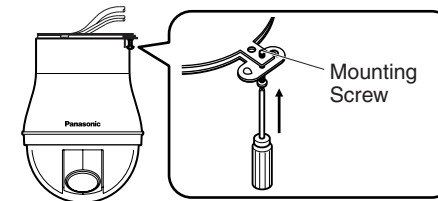

Remove the Camera Mounting Base by pulling up.

- 4 Cut the Diecast Case as shown.

Note: Be sure to protect the Video and Power Cables with the Protection Cover (provided).

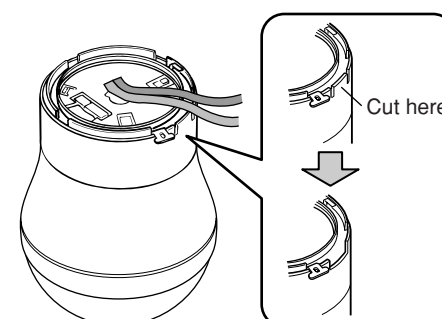

5 Remove the Decoration Cover in order (1) then (2).

The Decoration Cover can be removed by pressing on the points (1) at one place, and (2) at 4 places.

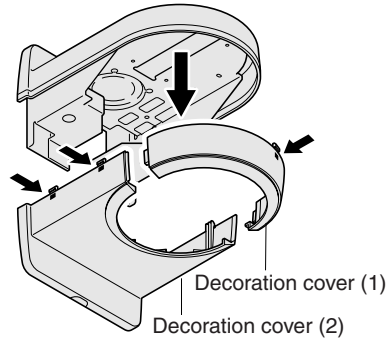

6 Fix the Camera Mounting Base (provided with the camera) to the bracket with the four M4-L8 Screws (provided).

Note: Be sure to fix the Camera Mounting Base in the up direction as shown.

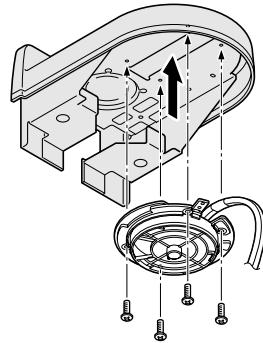

7 Run the cable around the outside and secure it with the clamp.

Secure the cable with the clamp so it goes along the inside of the top case so it does not get in the way when attaching the case and installing the camera.

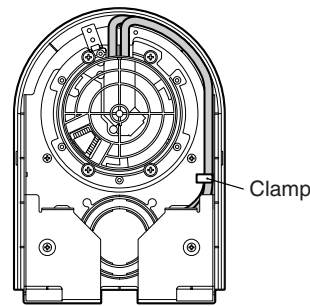

8 Attach the top case to the wall and run the cables.

Attach it with four screws. Screws are not provided. Align it with the position the camera will be installed.

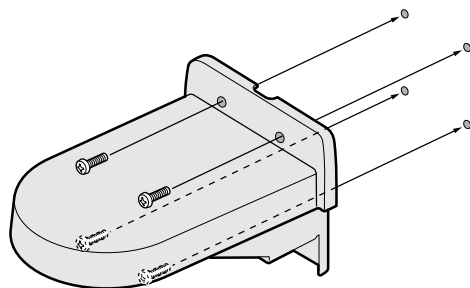

9 Place the removed Decoration Cover(2) back on the bracket and camera.

Note: Push the Decoration Cover up till it fits over the bracket with a click.

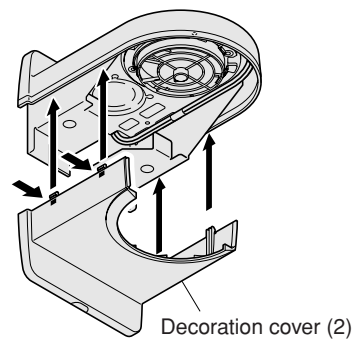

10 Suspend the Fall Prevention Wire from the Camera Mounting Base.

Notes:

- Make sure that the wire matches the Fall Prevention Wire Fixing Angle.
- The bracket is not shown in the illustration.

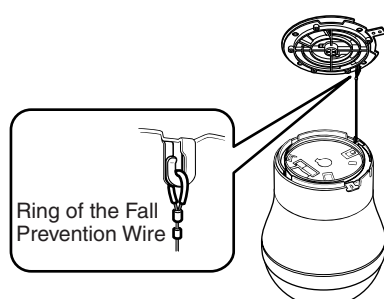

11 Attach the camera to the Camera Mounting Base, turn the camera clockwise, and tighten the Mounting Screw (M3, provided).

Notes:

- Tighten the Camera Fixing Screw with a screwdriver.
- In attaching the camera to the Camera Mounting Base, loosen the Camera Fixing Screw (M3), then tighten it back with a screwdriver while keeping it pushed up.
- The bracket is not shown in the illustration.

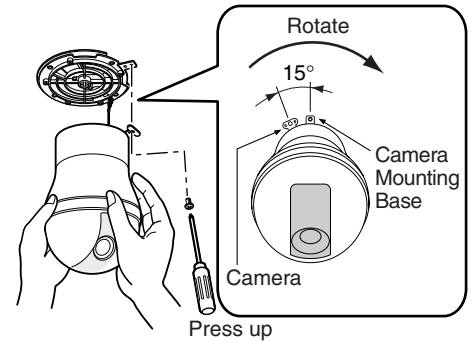

12 Place the removed Decoration Cover (1) back on the bracket and camera.

Note: Push the Decoration Cover up till it fits over the bracket with a click.

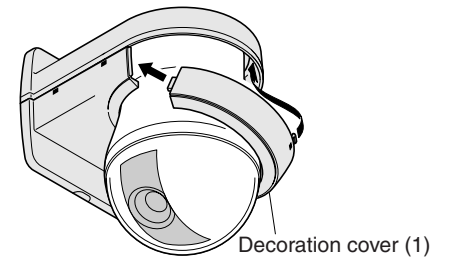

SPECIFICATIONS

Ambient Operating Temperature: 10°C - +50°C {14°F - 122°F}
 Dimensions: 165 (W) x 140 (H) x 217.5 (D) mm
 {6-1/2" (W) x 5-33/64" (H) x 8-37/64" (D)}
 Weight: 650 g {1.43 lbs}

Weight and dimensions indicated are approximate. Specifications are subject to change without notice.

STANDARD ACCESSORIES

Screw (M4-L8) 4 pcs.
 Template 1pc.
 Protection Cover 1pc.

For European and other fields:
Matsushita Electric Industrial Co., Ltd.
 Osaka, Japan
<http://www.panasonic.co.jp/global/>

For U.S. , Canadian and Puerto Rican fields:
Panasonic System Solutions Company,
 Unit Company of Panasonic Corporation of North America
Security Systems
www.panasonic.com/security
 For customer support, call 1.877.733.3689
Executive Office: Three Panasonic Way 2H-2,
 Secaucus, New Jersey 07094

Zone Office
Eastern: Three Panasonic Way, Secaucus, New Jersey 07094
Central: 1707 N. Randal Road, Elgin, IL 60123
Southern: 1225 Northbrook Parkway, Suwanee, GA 30024
Western: 6550 Katella Ave., Cypress, CA 90630

PANASONIC CANADA INC.
 5770 Ambler Drive, Mississauga,
 Ontario, L4W 2T3 Canada (905) 624-5010
<http://www.panasonic.ca>

Panasonic Sales Company
Division of Panasonic Puerto Rico Inc.
 San Gabriel Industrial Park 65th Infantry Ave. KM.
 9.5 Carolina, P.R. 00985 (809) 750-4300