

SONY
make.believe

NEX-FS100E
NEX-FS100EK

NXCAM Super 35mm Sensor Camcorder

A New World of High Quality Video Production Convenience with
an NXCAM Super 35mm Motion Picture Camcorder



NXCAM

AVCHD

MPEG2 SD

Exmor™
Super35 CMOS

MEMORY STICK™

SD™
XC

GPS

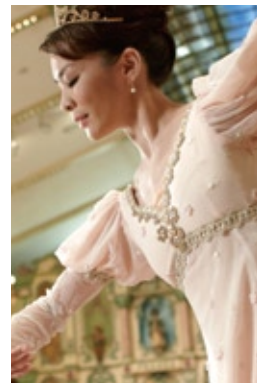

INTRODUCTION

NXCAM Super 35mm Motion Picture Camcorder Providing an Easy Way to High Quality Video Production

Sony's range of NXCAM models now includes the NEX-FS100 interchangeable lens camcorder featuring a Super 35mm sensor. Developed specifically for shooting motion pictures, this high sensitivity, large format sensor is capable of producing footage with shallow depth of field similar to that of a film camera for a new level of expression.

For even more creative flexibility, the NEX-FS100 also enables extended continuous recording and simultaneous recording of HD video footage for instant backup with an HXR-FMU128 Flash Memory Unit. These and other valuable features make this compact, high performance camera ideal for producing everything from low budget commercials, music videos and documentaries to wedding videos.



SENSOR

"Exmor" Super35 CMOS Sensor for Shooting Motion Pictures

Equipped with a large CMOS sensor equivalent in size to Super 35mm film, like that used in the PMW-F3, the NEX-FS100 enables shooting with the same creative field of depth as a film camera.

The sensor also features the optimum number of effective pixels for shooting HD moving images. At a high 50fps in all-pixel scan mode, this allows images to be captured with less color aliasing, jaggedness and rolling shutter than regular DSLR cameras, while providing the sensitivity to shoot at a minimum illumination of 0.28lux*¹. Another advantage of "Exmor" technology is minimal noise when shooting low-light scenes.

* 1 When using a fixed shutter speed of 1/25, auto gain and an iris setting of F1.4

The SEL18200 lens supplied with the NEX-FS100EK enables shooting in illumination as low as 1.5lux when using a fixed shutter speed of 1/25, auto gain and auto iris

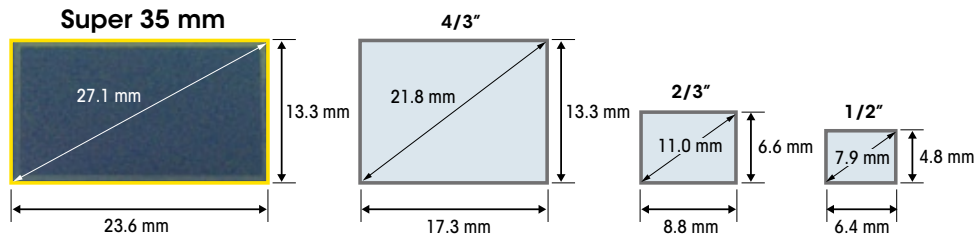

"Exmor" Super35 CMOS Sensor

Gross pixels	Approx. 3,530,000 pixels
Effective pixels of moving pictures in 16:9	Approx. 3,370,000 pixels
Effective pixels of moving pictures in 4:3	Approx. 2,530,000 pixels



Sensitivity



NEX-FS100

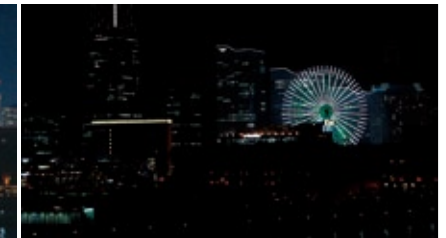

regular DSLR camera

Depth of Field



NEX-FS100

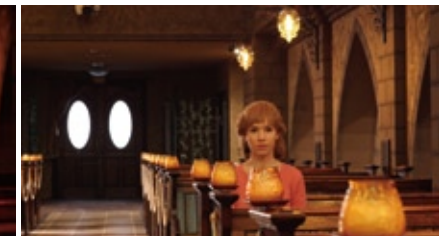

conventional camcorder

INTERCHANGEABLE LENSES

E-Mount Interchangeable Lens System

The NEX-FS100 features the E-mount Interchangeable lens system. Sony's E-mount interchangeable lenses let you enjoy a level of creative freedom unimaginable with camcorders of the past. All feature precision-crafted optics with aspherical glass elements for compact high performance, and circular iris mechanisms for smooth background defocusing. The supplied SEL18200(E 18–200mm F3.5–6.3 OSS) with the NEX-FS100EK boasts 11x zoom power, a quiet AF motor for cleaner sound recording, and Optical SteadyShot™ image stabilization with an advanced Active mode that lets you take steady handheld shots while walking around — even without a bulky stabilization rig. An ultracompact SEL16F28 wide-angle lens and SEL1855 3x zoom lens are also available. Thanks to the E-mount's short 18mm flange-back distance, using a mount adaptor allows shooting with a wide range of existing lenses. For example, with the LA-EA1 mount adaptor, you can take advantage of the abundant *a* lenses (A-mount lenses).



E-mount lens on the NEX-FS100



A-mount lens with the LA-EA1 adaptor

Another lens with a third party adaptor

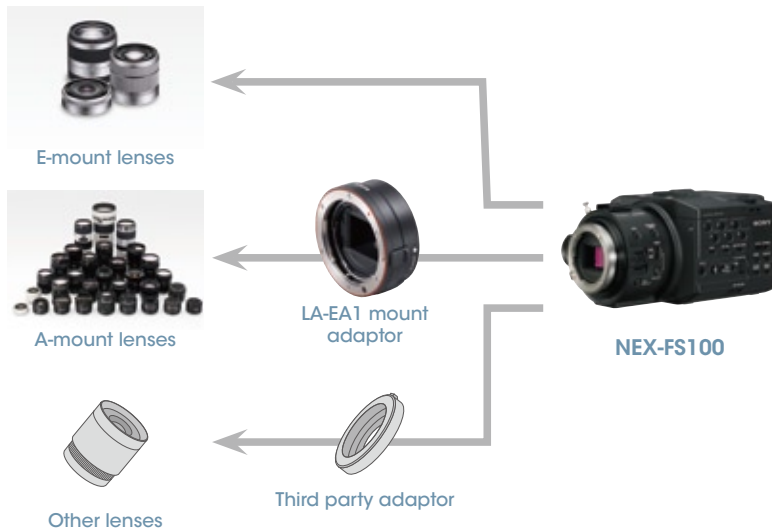

MODULAR DESIGN

New Design Concept Providing the Flexibility for a Variety of Shooting Styles

Featuring a compact, lightweight body with detachable grip, handle, and viewfinder, the NEX-FS100 is ideal for a wide range of shooting situations.



During hand-held shooting, the angle of the grip can be changed as desired, and recording started and stopped with a button on the grip. Recording start/stop buttons are also provided on the top and lower right of the camera.

There are also 1/4- and 3/8-inch screw holes on both the handle and the bottom of the camera body for mounting various peripheral devices. Plus a tape measure hook and an image sensor position index on the body.



Located on the optical axis, the 3.5-inch-type XtraFine™ LCD panel enables easier, more intuitive framing, especially during hand-held shooting. And the LCD panel can be rotated for stress-free operation when shooting low-angle scenes and digital signage footage. For easier, more precise focusing in daylight, the viewfinder comes with a detachable 1.2x magnifier.

CREATION

1920x1080P Slow and Quick Motion

Recording images at a different frame rate from that used for playback provides the extra versatility of slow and quick motion shooting. Furthermore, the NEX-FS100 enables Full HD (1920x1080) progressive slow and quick motion. Frame rates are selectable from among 50fps, 25fps, 12fps, 6fps, 3fps, 2fps and 1fps. So, for example, when recording at 1080/25p, if the frame rate is set to 50fps, images are recorded in 2.0 times slow motion. This means you can create impressive slow motion scenes without the need for troublesome editing.

Note: Shooting in slow and quick motion is possible during HD recording and in the progressive mode. And the simultaneous recording to a memory card and the flash memory unit is not possible.

Slow Motion Mechanism

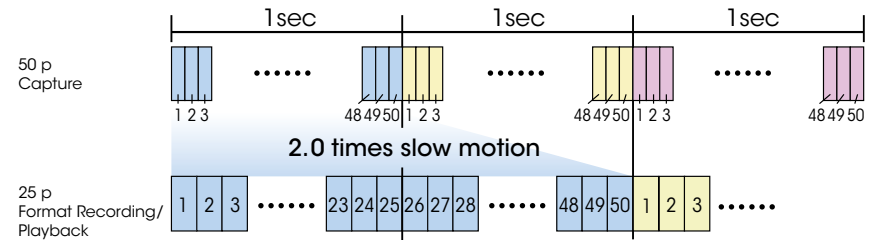

SAFETY & LONG RECORDING

Hybrid Recording



Recording to the directly mountable HXR-FMU128 Flash Memory unit allows continuous recording for over 10 hours without changing the recording medium. Simultaneous recording using memory cards and other media is also possible for secure backup when shooting footage that can't be reshot.

Note: HD and SD footage cannot be recorded separately on different recording media.



Available Memory Cards Type

* For detailed information please refer to the specification sheet on the back of this brochure.



Recording Time

HD MOVIE

		AVC HD 28M (PS)	AVC HD 24M (FX)	AVC HD 17M (FH)	AVC HD 9M (HQ)	AVC HD 5M (LP)
Linear PCM 2ch	1GB Memory Card	4 min	4 min	6 min	10 min	15 min
	2GB Memory Card	8 min	10 min	10 min	20 min	35 min
	4GB Memory Card	15 min	20 min	25 min	45 min	70 min
	8GB Memory Card	35 min	40 min	55 min	90 min	145 min
	16GB Memory Card	70 min	80 min	110 min	185 min	295 min
	32GB Memory Card	145 min	170 min	225 min	375 min	590 min
	HXR-FMU128 (128GB) [Optional]	600 min	700 min	940 min	1560 min	2460 min
Dolby Digital 2ch	1GB Memory Card	4 min	5 min	7 min	10 min	20 min
	2GB Memory Card	9 min	10 min	10 min	25 min	45 min
	4GB Memory Card	15 min	20 min	30 min	50 min	90 min
	8GB Memory Card	35 min	40 min	60 min	105 min	190 min
	16GB Memory Card	75 min	90 min	120 min	215 min	380 min
	32GB Memory Card	150 min	180 min	245 min	440 min	770 min
	HXR-FMU128 (128GB) [Optional]	640 min	750 min	1030 min	1830 min	3200 min

SD MOVIE

		SD 9M (HQ)
Dolby Digital 2ch	1GB Memory Card	10 min
	2GB Memory Card	25 min
	4GB Memory Card	55 min
	8GB Memory Card	110 min
	16GB Memory Card	225 min
	32GB Memory Card	460 min
	HXR-FMU128 (128GB) [Optional]	1910 min

Note: The recording time may vary depending on the recording conditions, subjects.

WORK FLOW

NXCAM Recording Format

Like other NXCAM series cameras, the new NEX-FS100 uses the AVCHD recording formats to enable stable operation without changing the conventional NXCAM workflow. Better still, it's ready to shoot with a maximum frame rate of 1920x1080/50p (28Mbps) for even higher quality recording. For more flexibility, recording MPEG-2 videos on SD memory cards is also possible.

HDMI Output with Embedded Time code for 4:2:2 Uncompressed Signal Output

For extra convenience when editing footage, the NEX-FS100 provides HDMI 4:2:2 output with an embedded SMPTE Time code.

For Windows® users

Use Content Management Utility Software to ingest

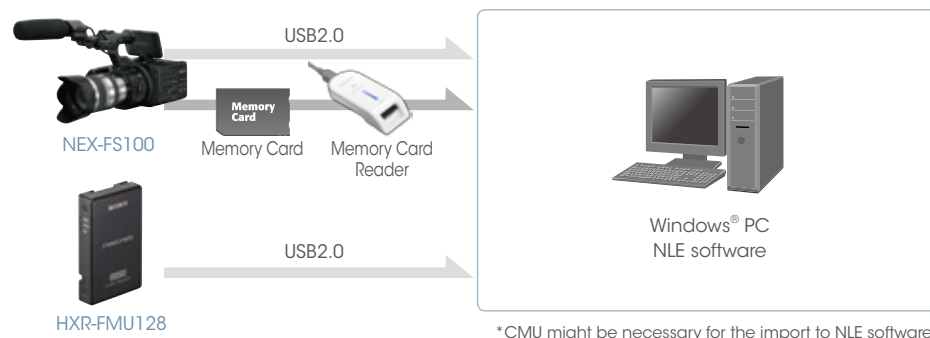

*CMU might be necessary for the import to NLE software.

For Final Cut Pro® Users

Use "Log & Transfer" and convert to ProRes422 to edit

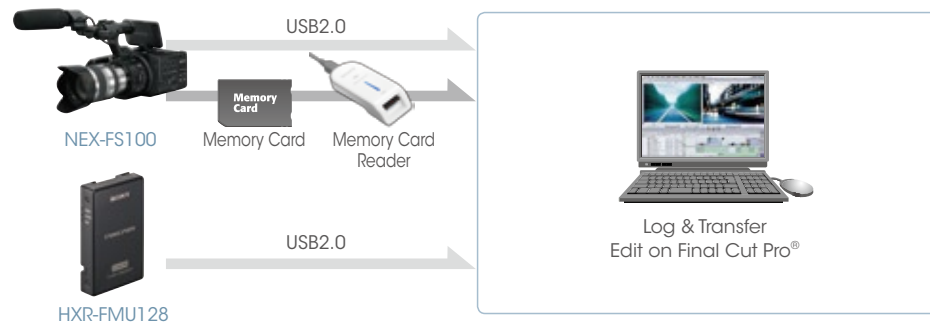

Utilize the HDMI output

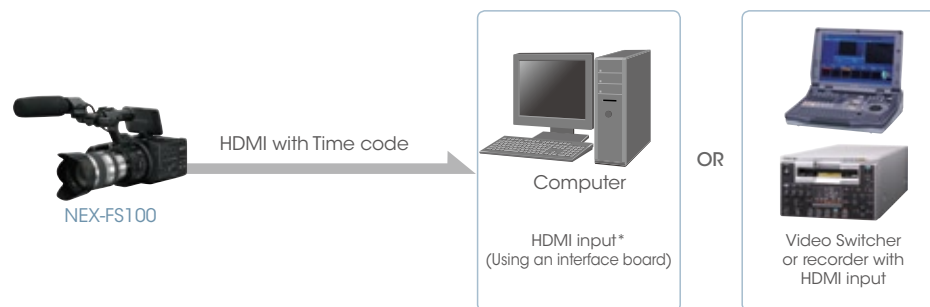

*Please contact the manufacturer for further detailed information

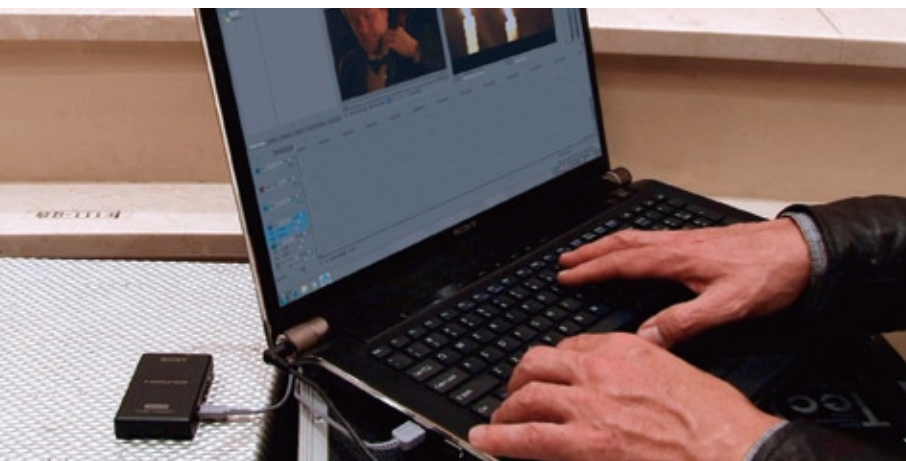

FUNCTION

Other Convenient Features

Location Simplification with GPS Technology

A built-in GPS function automatically records location information at the time of a shoot to AVCHD files. The supplied Content Management Utility (CMU) Version 2.0 software can also be used together with map software. This enables easy confirmation of exactly where footage was shot, which is particularly useful when shooting overseas.

Picture Profile™

Six picture profile settings for different shooting conditions are provided as default settings. Selecting a picture profile for a particular scene offers an easy way to change image quality.

Last Scene Review

Enables fast, one-touch confirmation of the last recorded scene without operating multiple buttons.



Expanded Focus

Press a button and this enlarges the center of the displayed image by 2x, a particularly useful feature when making critical focusing adjustments.

Histogram

Onscreen display of a histogram enables easier exposure adjustment. The histogram also shows the point where the zebra pattern appears (the zebra point). This enables confirmation of overall brightness distribution and the brightness level set with the zebra function. As well as preventing overexposure, this is useful as a guide when aiming for optimum exposure of certain parts of an image, such as faces.

Peaking

A peaking function draws a defined line around the subject displayed in the LCD monitor and viewfinder. Peaking sensitivity and color (red, white, yellow) can be selected to enable more precise focusing.

Markers

Center, aspect, safety zone, guide frame and other markers can be displayed on the LCD.

Firmware Update

Sony has implemented a firmware update scheme for future functions.

Sony Opens Up New Era of Super 35mm Digital Production





Available Accessories



2NP-F970/B
Rechargeable Battery Pack



AC-VQL1BP
AC Adaptor / Charger



VCT-SP1BP
Camcorder Support



VCT-SP2BP
Camcorder Support



HXR-FMU128
Flash Memory Unit



VCT-PG11RMB
Tripod with RM-1BP Remote
Controller



HVL-LBPB
Battery Video Light



LPM-770BP
Portable Monitor



LCS-G1BP
Soft Carrying Case



LCS-BP1BP
Soft Carrying Case



LCH-GT1BP
Hard Carrying Case



RM-1BP
Remote Commander



MS-HX32A (32 GB, 16 GB, 8 GB)
Memory Stick PRO-HG Duo™
MS-MT32G (32 GB, 16 GB, 8 GB, 4 GB, 2 GB)
Memory Stick PRO Duo™



SF-32N4 (32 GB, 16 GB, 8 GB, 4 GB, 2 GB)
SD / SDHC Memory Card

Specifications

Dimensions

Unit: mm (inches)

NEX-FS100

General			
Mass	Body only	Approx. 1.04 kg (2 lb 4oz)	
	w/optional lens w/VF, w/ Battery (NP-F970), w/large eyecup, w/handle, w/MIC (ECM-XM1), w/grip, w/o gripbelt	Approx. 2.76 kg (6 lb 1oz)	
Dimension (W x H x D)	Body only	Approx. 126.5 x 101.5 x 193.5 mm (5 x 4 x 7 5/8 inch)	
	w/optional lens, w/VF, w/large eyecup, w/handle, w/MIC (ECM-XM1), w/grip, w/o gripbelt	Approx. 178 x 192 x 519.5mm (7 1/8 x 7 5/8 x 20 1/2 inch)	
Power requirements	Power Requirements (AC adaptor / Battery)	8.4V / 7.2V	
Power consumption	w/ ECM-XM1 and LCD with normal brightness	5.6W (w/ supplied lens) *When Flash Memory Unit HXR-FMU128 is used, the average power consumption increases about 1.1W	
Operating temperature		0 to +40 deg C (+32 to +104 deg F)	
Storage temperature		-20 to +60 deg C (-4 to +140 deg F)	
Continuous Recording Time	Continuous Recording Time	Approx. 510 min (NP-F970 fully charged batt.)	
Recording format	Video Format	HD	MPEG-4 AVC/H.264 AVCHD format compatible (1080/50p original format)
		STD	MPEG-2 PS
	Audio Format	HD	Linear PCM 2ch, 16bit, 48kHz / Dolby Digital 2ch, 16bit, 48kHz
		STD	Dolby Digital 2ch, 16bit, 48kHz
Recording frame rate*		HD PS (28Mbps) 1920x1080/50p, HD FX (24Mbps) 1920x1080/50i, HD FH (17Mbps) 1920x1080/50i, HD HQ (9Mbps) 1440x1080/50i, HD LP (5Mbps) 1440x1080/50i, HD FX (24Mbps) 1920x1080/25p, HD FH (17Mbps) 1920x1080/25p, HD FX (24Mbps) 1280x720/50p, HD FH (17Mbps) 1280x720/50p, SD/STD HQ (9Mbps) 720x576/50i	
Recording/Playback time		170 min (2h 50m) with 32GB Memory Stick PRO-HG Duo HX at FX(24Mbps) Linear PCM 2ch recording	
Lens (supplied with NEX-FS100EK)			
Lens Mount		E-mount	
Model Name		SEL18200	
Product Name		E 18-200mm F3.5-6.3 OSS	
Equivalent 35mm-format focal length	16:9	28.8 - 320mm	
	4:3	36- 400mm	
Zoom ratio		11.1x	
Filter Diameter		67mm	
Camera Section			
Imaging device		*Exmor™ Super35 CMOS Sensor	
Imaging device	Gross pixels	Approx. 3,530,000 pixels	
	Effective pixels of moving pictures in 16:9	Approx. 3,370,000 pixels	
	Effective pixels of moving pictures in 4:3	Approx. 2,530,000 pixels	
Minimum illumination		0.28 lx (1/25 shutter, IRIS F1.4, Auto GAIN) **	
Shutter speed	Auto	50i/50p, 1/50-1/1750, 25p, 1/25-1/1750	
	Manual	1/3 - 1/10000 1/50 - 1/1750 (50i, 50p), 1/25 - 1/1750 (25p)	
Slow & Quick Motion function	Rec Format	1080/50p, 1080/25p	
	Frame Rate	50fps, 25fps, 12fps, 6fps, 3fps, 2fps, 1fps	
	Shutter Speed	1/scan frame rate - 1/10000(Manual)	
White balance		Auto, Outdoor(5800K), indoor(3200K), One-push (Touch panel)	
Inputs/Outputs			
Audio input		XLR 3-pin (female) (x 2), LINE/MIC/MIC +48 V selectable	
Composite output		RCA Type (x 1)	
Audio output		RCA type (CH-1, CH-2)	
Component Video Output		RCA Type (x 3) via Mini-D jack	
USB		USB device, mini-AB/Hi-Speed (x 1)	
Headphone output		Stereo mini jack (x 1) ø3.5mm	
Remote		Stereo mini-minijack (ø2.5mm)	
HDMI output		HDMI connector (x 1)	
Built-in LCD monitor		3.5 inch-type, XtraFine LCD, approx. 921,600 dots(1920 x 480), 16:9 aspect ratio	
Recording Media			
Type		Memory Stick PRO Duo (Mark2), Memory Stick PRO-HG Duo, Memory Stick PRO-HG Duo HX, SD/SDHC/SDXC Memory Card***	
Supplied Accessories			
		AC Adaptor/Charger (AC-VL1), Rechargeable Battery Pack (NP-F770), Connecting cord (DK-415), Microphone (ECM-XM1), Remote Commander (RMT-845), Component video cable, AV connecting cable, USB cable, USB Adaptor Cable (VMC-UAM1), Large eyecup, Lens (SEL18200), Lens hood with lens cover, Accessory shoe kit, Lithium Battery (CR2025), Clock Lithium (Installed), Application Software (CD-ROM) (CMU2.0)	

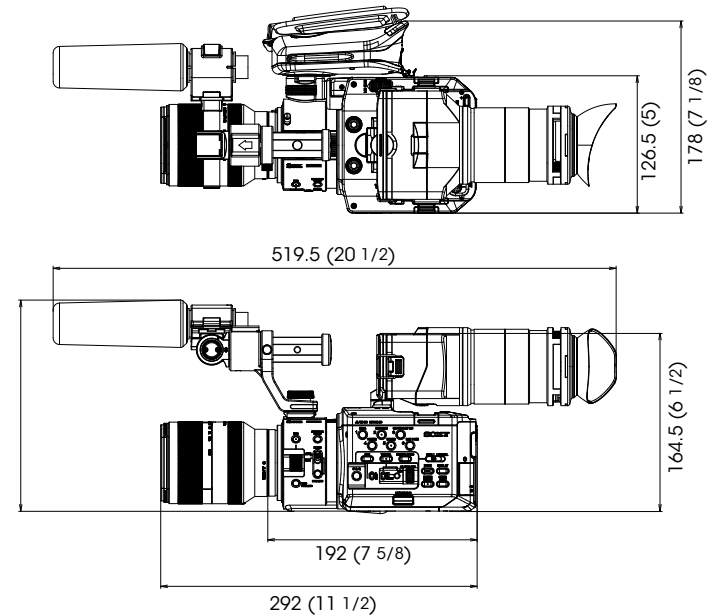

Body only

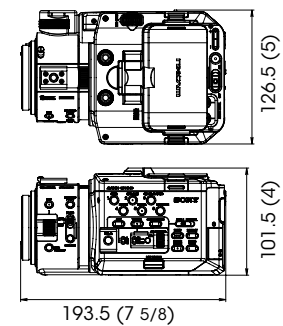

HXR-FMU128

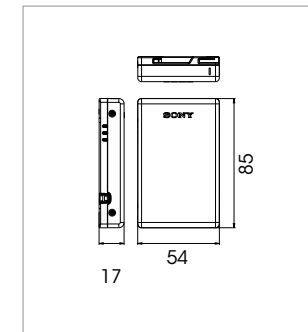

* Due to variable bitrate, 24Mbps is the maximum bitrate for AVCHD FX mode and the average bitrate is being stated for FH, HQ and LP modes.

** 1.5 lx (w/ supplied lens: auto gain, auto iris, 1/25 shutter speed)

*** Class 4 or higher

SONY
make.believe

Distributed by

MK10847V1OHB11MAR

© 2011 Sony Corporation. All rights reserved.
Reproduction in whole or in part without written permissions is prohibited.
Features and specifications are subject to change without notice.
The values for mass and dimension are approximate.
Sony and Sony logo are trademarks of Sony Corporation.
NXCAM and NXCAM logo are trademarks of Sony Corporation.
Exmor, SteadyShot, InfoLITHIUM, Memory Stick, Memory Stick PRO Duo, Memory Stick PRO-HG Duo and their respective logos are trademarks of Sony Corporation.
XtraFine, Picture Profile are trademarks of Sony Corporation.
AVCHD and AVCHD logo are trademarks of Panasonic Corporation and Sony Corporation.
Windows is a registered trademark of Microsoft Corporation in the United States and other countries.
Mac and Final Cut Pro are trademarks of Apple Inc.
Dolby is a trademark of Dolby Laboratories.
SD, SDHC and SDXC logs are trademarks of SD-3C, LLC.
All other trademarks are the property of their respective owners.