

SRX-R320

4K Digital Cinema Projector

SONY
make.believe

LMT-300

Media Block

STM-100

Theater Management System



Sony Digital Cinema™
4K

The Standard of 4K Digital Cinema - Sony's Integrated Projection System

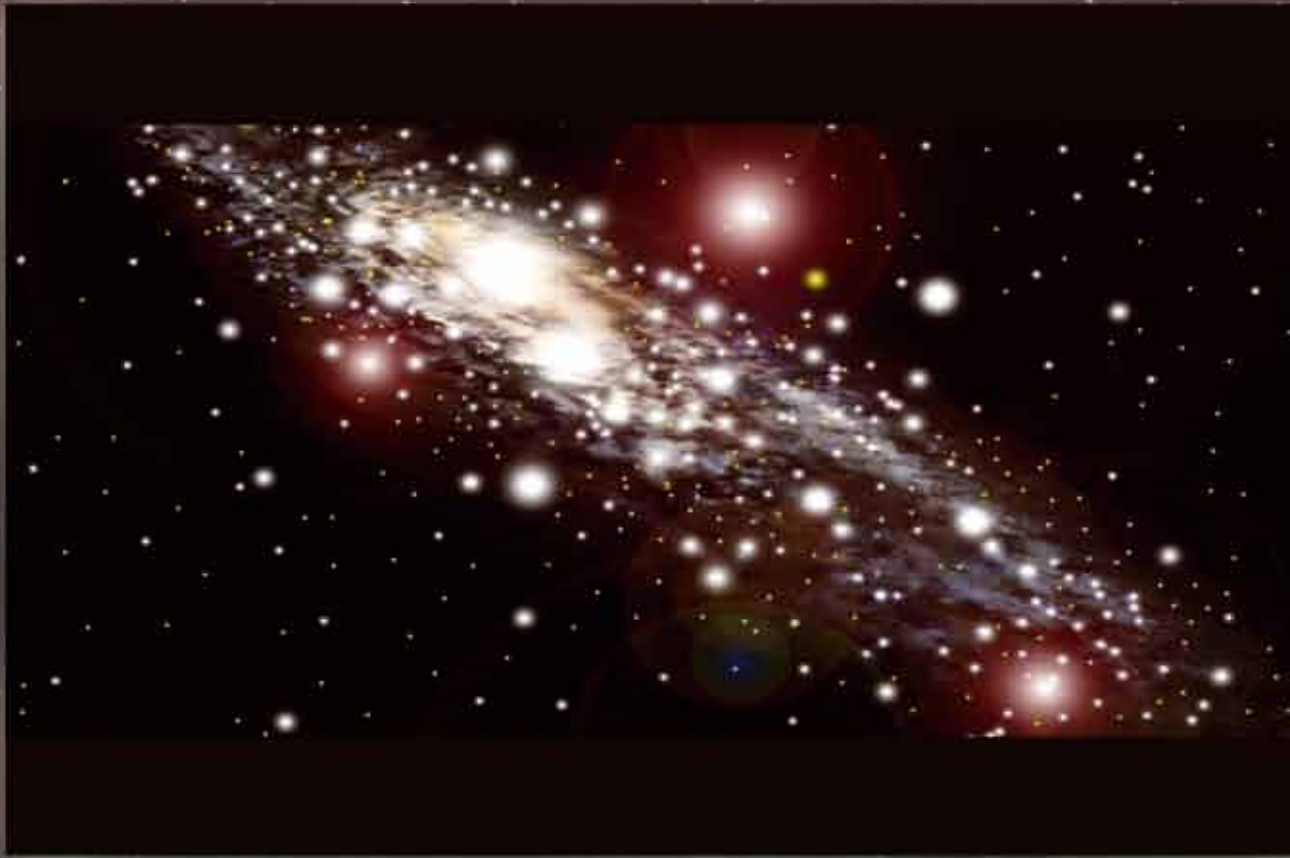

World-first DCI Specification-compliant 4K Digital Cinema Projection System Combines a Cinema Server and 4K Projector

In 2009, Sony introduced an ultra-high-resolution 4K digital cinema projection system combining an SRX-R320 4K SXRD projector and an LMT-300 Media Block. Since its sensational debut, this complete system has rapidly acquired a huge reputation among a range of users worldwide due to its advanced features and functionalities specifically designed for digital cinema applications.

In March 2011, Sony announced that this system was the world's first to successfully complete the full range of compliance tests for the DCI specification - the Digital Cinema Initiatives, LLC (known as DCI) is a joint venture of six major Hollywood studios*. As a result, this DCI specification-compliant system is now called Sony's Integrated Projection System.

The SRX-R320 projector is equipped with three Silicon X-tal Reflective Display (SXRD™) devices, delivering an amazing resolution of 4096 x 2160 pixels (H x V) - more than four times the resolution of full HDTV (1920 x 1080), and achieving a high contrast ratio of more than 2000:1.

The LMT-300 Media Block is a digital cinema server that incorporates hard disk drives (HDDs) with a large storage capacity of approximately 1.7 TB and adopts a reliable RAID (Redundant Array of Inexpensive Disks) system. It can play back DCI DCP (Digital Cinema Package) files and allows the SRX-R320 projector to show digital cinema programs. Another unique feature of the LMT-300 is its Screen Management System function, which is equipped as standard and can provide a variety of screen-management operations such as show scheduling, communication with other theater control systems (eg, lighting and curtains), and setup and maintenance of the projector.

Moreover, this projection system offers optional STM-100 Theater Management System software that allows theater staff to efficiently manage multiple auditoriums from a central PC connected to the theater LAN.

With extremely high resolution, outstanding security, and operational versatility, Sony's Integrated Projection System based on the SRX-R320 4K projector is a perfect choice for digital cinema applications.

* The six major Hollywood studios are Walt Disney Company, Sony Pictures Entertainment, Inc., 20th Century Fox, Paramount Pictures Corporation, Warner Bros. Entertainment Inc., and Universal Studios Inc.



SRX-R320 with LKRA-003 Touch Panel Monitor attached

System Advantages/Features

4K Resolution

Historically, the movie theater experience has always exceeded that achieved by home entertainment systems. The advent of HDTV (1920 horizontal pixels) and technical improvements in home theater equipment have stimulated the movie industry to think further ahead into the future. Meanwhile, the Hollywood movie studios have jointly agreed on standardizing 4K (4096 horizontal pixels) and 2K (2048 horizontal pixels) as the next-generation digital movie distribution and projection standards. Creating movies in 4K protects the future value of the content, and also provides a significant benefit to the theater audience. In recent years, stadium-type seating is becoming increasingly popular among modern cinema complexes. By sitting closer to the screen, the audience can enjoy a more immersive visual experience. However, those sitting in the front rows may witness pixel artifacts when the resolution provided by the projection system is not sufficient to fill the screen size. The SRX-R320 provides true 4K output, which reproduces the full detail of 4K content thanks to the 4K SXRD panels, 4K internal signal processing, and 4K-compatible optical system. Besides, since the SRX-R320 provides four times the resolution of 2K projectors, the visual quality of 2K and HD content is also improved over those provided by native 2K and HD-resolution projectors.

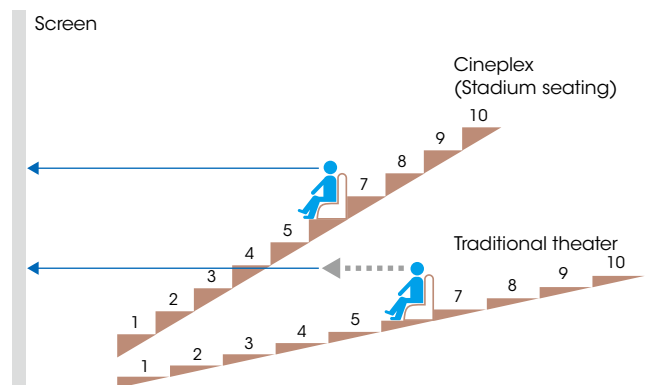

High 2000:1 Contrast Ratio

The SRX-R320 offers a high contrast ratio of more than 2000:1 through the use of Sony's unique SXRD device. The SXRD device itself achieves a contrast ratio of over 4000:1. This stunning picture quality makes the SRX-R320 ideal for applications in which dynamic range is essential. The high contrast ratio has been achieved through two key technologies – the 'normally black mode' system and an extremely thin liquid crystal cell gap.

Xenon Lamp Provides Highly Bright and Pure Light Source

The SRX-R320 provides a high brightness on a wide screen using a Xenon lamp. A Xenon lamp provides pure, superb color tonal reproduction essential to meeting the stringent requirements of digital cinema. Xenon lamps, which are designed for the SRX-R320 and available from lamp manufacturers, satisfy the wide color range required for digital cinema by dispersion at a very flat and wide light spectrum.

Available Xenon Lamps

Sony-recommended Xenon lamps for the SRX-R320 are available from lamp manufacturers such as USHIO, OSRAM, and PHILIPS. For detailed information on the lamps, please contact your nearest Sony or lamp manufacturer's office.

Variety of High-quality Lenses

Three optional zoom lenses are available for the SRX-R320. All lenses utilize very large image circles that contribute to minimizing the optical vignetting that typically occurs on projector lenses, and to obtaining the highest possible values of MTF (Modulation Transfer Function). With these features, the optical systems of the SRX-R320 have the capacity to reproduce resolutions higher than 4K, which is necessary to project 4K content exactly at 4K resolution. In addition, these lenses are designed to minimize chromatic aberrations using Sony's accumulated technical knowledge.



LKRL-Z211



LKRL-Z214



LKRL-Z219

Variety of Interfaces

The SRX-R320 supports a wide variety of signal formats including the 12-bit X'Y'Z' signal that is stipulated in the DCI specification. 10-bit 4:4:4 RGB and 10-bit 4:2:2 YPbPr signal formats are also supported for playback of other alternative content.

- Two channels of SRLV (Sony original multi-pin interface), which are used for connection to the LMT-300 Media Block (for 4K projection: 4K DCP).
- A DVI (HDCP) interface that accepts DVI (HDCP) signals for up to 2048 x 1080 at 60 FPS (for 2K projection).
- A dual-link HD-SDI/DC-SDI input* that accepts any of the following signals:
 - For HD projection: SMPTE 372M dual-link HD-SDI (4:4:4), or SMPTE 292M HD-SDI (4:2:2)
 - For 2K projection: DualLink DC-SDI (RGB 4:4:4), DC-SDI (YPbPr 4:2:2), or 12-bit X'Y'Z' signals (4:4:4)

* To support this input, the optional LKRI-003 board is required.

Operational Features

3D Projection Lens Unit

Attaching the 3D projection lens unit to its lens mount, the SRX-R320 can deliver crisp 3D images*. It allows full 2K resolution for the left and right eyes simultaneously, resulting in a high-brightness, high-quality stereoscopic cinema presentation that offers more faithful reproduction of motion in 3D.

*To produce 3D images on a screen, 3D systems available from 3D system integrators are required. For detailed information on the 3D systems, please contact your nearest Sony office.



SRX-R320 with 3D projection lens unit attached

Sony Digital Cinema™ 3D

Anamorphic Lens

When projecting digital cinema content created in the CinemaScope format (4096 x 1716 pixels), the SRX-R320 cannot use all of the 4096 x 2160 pixels available for the 4K SXRD device. To improve this inefficiency, the optional LKRL-A001 Anamorphic Lens with Lens Changer Unit* was developed. When CinemaScope images (4096 x 1716 pixels) are input, the SRX-R320 extends them in a longitudinal direction via the projector's image-processing function, which effectively uses all the pixels of the SXRD device. The LKRL-A001 attached** in front of the projector's

lens extends the images in a transverse direction, so that the aspect ratio of the images projected on a screen can be restored to its original 2.39:1. This can increase the brightness level of the images on the screen by approximately 20%, allowing for the projector to provide a high brightness on large screens.

The LKRL-A001 includes a lens-changer function that can set the anamorphic lens not to be in use manually. This function allows for the SRX-R320 to accept digital cinema content created in the Flat format (3996 x 2160 pixels), without dismounting the LKRL-A001 unit from the projector.

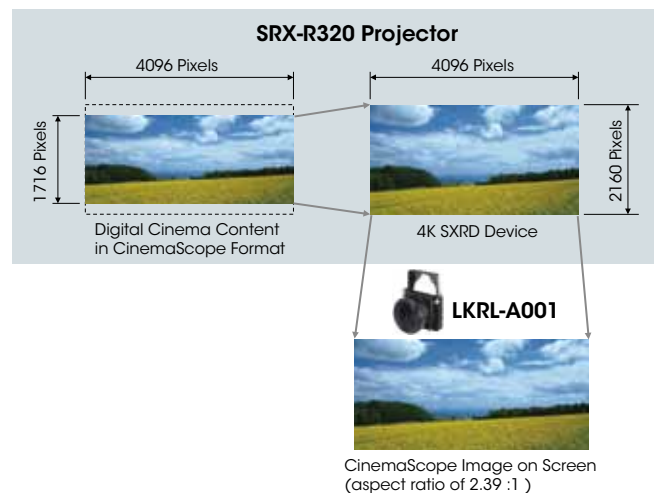

* The LKRL-A001 supports 2D projection lenses. For detailed information, please contact your nearest Sony office.

** To attach the LKRL-A001 to the projector, lens support stays are required. For detailed information, please contact your nearest Sony office.



SRX-R320 with LKRL-A001 attached;
anamorphic lens not in use

Anamorphic Mode Function

The SRX-R320 allows squeezed images (16:9 or 1.896:1) to be changed to 2.39:1 un-squeezed images. This can be done electrically without an anamorphic lens.

Color Space Conversion (CSC) Function

The SRX-R320 features a Color Space Conversion (CSC) function, which helps users easily adjust the projector's color space to that which is defined in the DCDM (Minimum D-Cinema Color Gamut) or ITU-R BT.709. The target color gamut parameters required to meet the DCDM or ITU-R BT.709 standards can also be applied to the projector with this function. The internal test generator simplifies adjustment and lets the operator align the projector in minutes.

Gamma Curve Selection

The SRX-R320 provides three preset gamma curve values. Users can select an optimum value from 1.8, 2.2, and 2.6 according to the desired color tone.

Lens Shift Function

The SRX-R320 is equipped with a lens shift function that allows projected images to be moved up and down or from side to side. This lens shift function can be operated manually via the finger screws incorporated on the projector's unit. Using this function, the position of the projected images can be moved vertically and horizontally.

Keystone Masking

To compensate for keystone distortion, which typically occurs when the projector is not installed directly in front of the screen, the SRX-R320 has an image-masking function. To determine the best position for the masking, this function allows users to set further two points in addition to the four corner points, which is particularly useful when projecting onto a curved screen.

Select four corner positions to mask the area outside the perimeter.



For curved screens, select two positions at the apex of the curve, one at the top and one at the bottom of the screen.

Zoom/Focus Memory Function

The SRX-R320 is equipped with zoom and focus memory functions that make it easy to switch the projection between two types of aspect ratios.

When used with an optional zoom lens - such as the LKRL-Z211, LKRL-Z214, or LKRL-Z219 - the zoom and focus positions for the 1.85:1 Flat screen format and 2.39:1 CinemaScope can be stored in the projector's memory and then instantly recalled from there. This allows for full-screen display regardless of the aspect ratio. An electronic vertical alignment feature is included in the same memory to compensate for vertical changes in the image, should the projector be mounted at a downwards angle.

Maintenance and Security Features

Easy Maintenance of Luminance Level

During long periods of usage, users commonly have to adjust the luminance level of their projector, as Xenon lamps typically get darker over time. The SRX-R320 has a convenient function to help users know when to make such adjustments. It allows users to set a standard luminance level, and displays an alert message on the LCD screen of the projector when the value changes from the standard level. With this feature, proper and timely maintenance of the luminance level can be performed.

Automatic Lamp Power Calibration Function

When switching the aspect ratio of projection from CinemaScope to VistaVision and vice versa, the luminance levels happen to change. To maintain a constant luminance level even after making these changes, the SRX-R320 can automatically calibrate the luminance level by controlling the lamp output power.

Air-flow Sensor for Reliable Cooling

The SRX-R320 has a chimney on top of the unit that expels warm air, thereby keeping the projector unit cool. The chimney has an air-flow sensor that measures the amount of discharged air. When the projector is powered on from Standby mode, the air-flow sensor operates automatically. If the value does not reach a normal level, an alert message is displayed on the projector's LCD screen. Thanks to this function, the operator can immediately take proactive maintenance action, allowing for reliable projector cooling.

Power Supply and Control of External Ventilation Fan

To efficiently discharge warm air from the unit, the chimney of the SRX-R320 projector must be connected to an exhaust duct with a ventilation fan. For optimum reliability and effectiveness, the projector supports an Interlock interface, which enables the SRX-R320 to operate this external ventilation fan. The projector can supply power to the fan and control its operation – the fan works when the projector is in Lamp ON mode or Standby ON mode.

Anti-tamper System

The SRX-R320 is designed to be highly secure. It does not have screw holes, and requires physical keys to open the enclosure. This body structure meets the anti-tamper requirement of the DCI. Even if the enclosure is opened with the physical keys, anti-tamper sensors will trigger the LMT-300 Media Block to immediately start recording logs for further safety. In this case, the projector also deletes Key Delivery Messages (KDM) automatically, so that DCP files cannot be played back.



SRX Controller Software

The SRX Controller software* is a convenient tool for system integrators to set up and maintain the SRX-R320. This runs on a PC** connected to the projector via the RS-232C interface, and features intuitive GUIs that enable easy setup and adjustment of the projector. A comprehensive range of setup parameters including input configurations, colorimetry controls, installation adjustments, and maintenance settings can be controlled via this software. For example, it allows operators to easily verify a lamp's operating time. Plus, the versatile projector functions such as Squeeze Mode, Color Space Conversion (CSC), and Zoom/Focus Memory can also be controlled via this software.

* For detailed information on availability of the SRX Controller software, please contact your nearest Sony office.

** System requirements for the SRX Controller software: Microsoft® Windows® XP Professional and Windows 7. Supported OS languages are English and Japanese only.

In addition to its extreme resolution and high contrast, the SXRD device used in the SRX-R320 projector has the following remarkable technological features:



'Normally Black Mode' System

In every type of projection system, displaying absolute black is a major issue – as this helps to achieve a high contrast ratio. In other words, the contrast ratio of a projector depends on how effectively the light from the source can be blocked, so it does not leak through the display device. All Liquid Crystal Display (LCD) devices control the amount of light to be projected by applying an electric field to the liquid crystal gap. In typical LCD devices, black is produced when an electric field is applied across the liquid crystal cell gap. However, molecules near the surface of the glass substrate may not be accurately controlled due to the influence of the alignment film. This is not an issue for bright images but, when displaying dark images, light may tend to leak from the LCD device, since the molecules near the surface are less accurately controlled. This results in a creamy black instead of a deep black. The SXRD device does not exhibit these characteristics. This is because the 'normally black mode' system displays black when the electric field is not applied and, because all molecules are in the correct alignment, the polarized light alignment is also optimized. The direct result is a far deeper black level, leading to a high contrast ratio.

Thin Liquid Crystal Cell Gap

Another important factor allowing for the high contrast of the SRX-R320 is the SXRD device's ultra-thin cell gap of less than 2 micrometers. With conventional 'vertically aligned liquid

crystal' systems, a thin cell gap could not be achieved. Sony has overcome this difficulty through the use of innovative planarization technology in the silicon backplane structure and an advanced silicon wafer-based assembly process. The SXRD device also adopts a structure that does not use 'spacers'. These are columns found in conventional reflective liquid crystal devices to maintain a constant gap between the liquid cell floor and the top of the device. Spacers tend to both scatter and reflect light, which can impair high-contrast pictures. In the spacer-less SXRD device, these artifacts are no longer seen.

Short Response Time

The thin cell gap structure in SXRD devices also contributes to an ultra-fast response time of 2.5 milliseconds (for both rise and fall). The SXRD device reacts promptly to an instantaneous change of picture content, enabling SXRD-based projectors to display smooth motion. Consequently, the SRX-R320 virtually eliminates motion blur; a particularly significant benefit when presenting content that includes fast-moving objects.

Thermal Management by Peltier Device

The SRX-R320 adopts an advanced thermal management system that combines a Peltier device and a thermal sensor. The Peltier device is placed at the back of the SXRD device to cool or heat the panel by applying current. The thermal sensor attached to the panel measures the panel temperature and feeds back this data to the Peltier device so that the temperature can be precisely controlled. Thanks to this system, the SXRD device is maintained under temperature conditions that optimize performance.

12-bit SXRD Driver

The SRX-R320 utilizes a 12-bit display panel driver for reproducing extremely natural images.

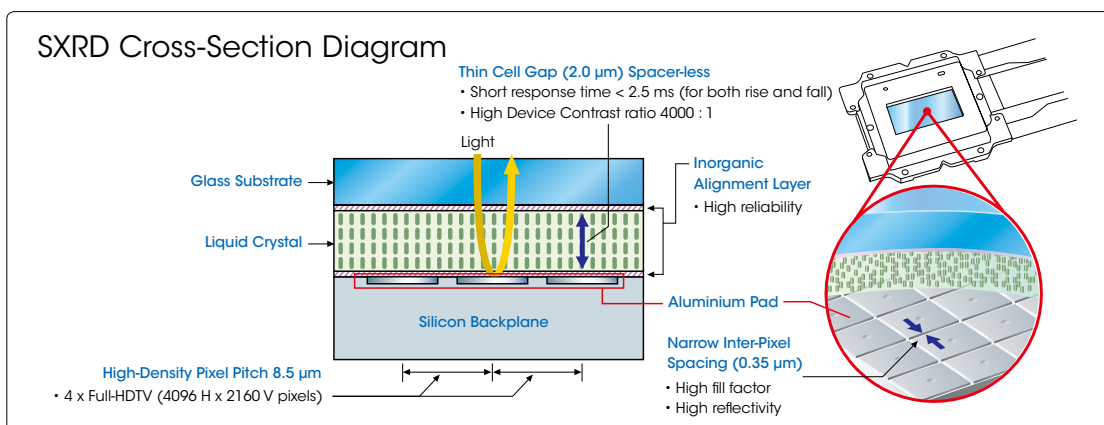

Digital Cinema Server – LMT-300 Media Block

The LMT-300 Media Block is a digital cinema server with a large storage capacity and high reliability. It can be seamlessly integrated into the chassis of the SRX-R320 projector, allowing for a highly secure DCI specification-compliant Integrated Projection System. The LMT-300 can handle DCI DCP (Digital Cinema Package) files that consist of picture, audio, and subtitle data files, and that are wrapped into an MXF (Material eXchange Format) file. It can play back the DCP file by using advanced processing to decrypt and decode the picture data, and then send it to the projector over a secure multi-pin connection system. Moreover, the LMT-300 incorporates the Screen Management System (SMS) function, which lets operators manage all of the devices necessary for digital cinema presentation from one location.

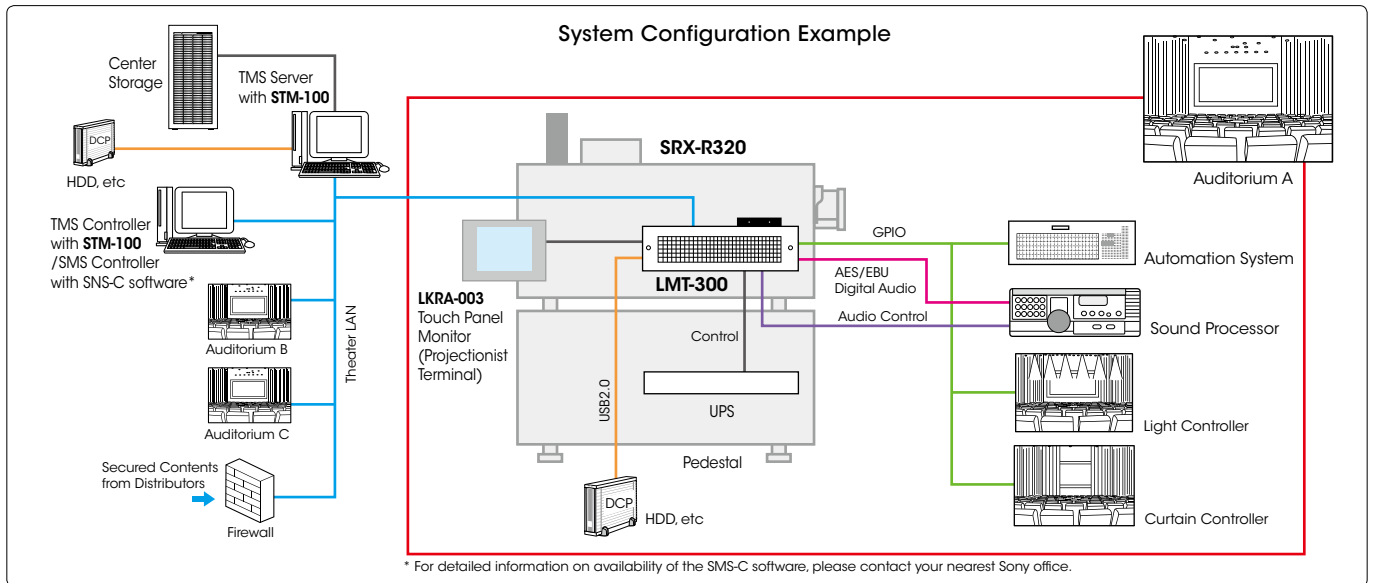
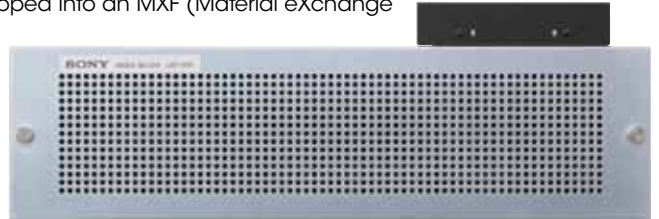

Large Storage Capacity and Reliable RAID System

The LMT-300 incorporates HDDs with a large storage capacity of approximately 1.7 TB. It employs a Modified RAID 6 (Redundant Array of Inexpensive Disks) system that allows for highly reliable digital cinema presentation.

Decryption and Unwrapping of DCP Files

The LMT-300 can decrypt DCP files that have been encrypted using the AES (Advanced Encryption Standard FIPS 197). It can also unwrap individual picture, audio, and subtitle data files for processing that are encoded within the MXF file.

Picture and Subtitle

The LMT-300 can decode JPEG 2000 picture data in real time for playback, regardless of whether the file was encoded at 2K or 4K resolution. Subtitles in Timed-Text/XML or PNG/XML format can be overlaid onto picture data before it is sent to the projector.

Audio

The LMT-300 transcodes audio DCP files into AES/EBU digital audio signals, and then outputs them from two audio output connectors (D-sub 25-pin) to external audio processors such as Dolby® sound processors. The audio output 1 and audio output 2 can support up to 8 and 16 channels, respectively. The timing of the audio output can be adjusted for complete synchronization with the picture, and any channel can be routed to any output to simplify installation.

Log Creation

The LMT-300 can generate logs to record certain information – such as the number of times a movie has been played – which is a DCI requirement for secure content control.

Ingest of DCP Files During Playback

DCP files can be ingested to the LMT-300, even while playing a movie.

Screen Management System

As standard, the LMT-300 incorporates the Screen Management System (SMS). Thanks to this SMS function, the operator can perform a variety of functions required for digital cinema presentation via the touch-panel screen of a projectionist terminal attached to the projector. This SMS function can also be operated remotely from a PC* connected to the theater network. In addition, the SMS can be seamlessly integrated with other theater systems that have the optional STM-100 Theater Management System software installed, as well as third-party auditorium automation systems.

The SMS of the LMT-300 satisfies the requirements of the DCI specifications version 1.2 for screen management and security.

*To support the SMS controller functions, the SMS controller software must be installed on the PC. For detailed information on its availability, please contact your nearest Sony office.

Screen Management Functions Operated by a Projectionist Terminal:

- DCP ingest/registration and DCP management
- Key Delivery Message (KDM) registration and key management
- Show Play List (SPL) creation and management
- Show schedule viewing
- Playback control
- Execution of SPLs
- Device configuration
- Device monitoring
- Status monitoring: collect status information from the projector and Media Block; report status at pre-configured intervals
- Monitoring of cavity security status from Media Block
- Automation system interface
- Projector Power On/Standby control
- Lamp Power On/Off control
- Adjustment of lamp power values
- Adjustment of the lamp bulb's z-axis
- Lamp serial code input function when installing a new lamp bulb
- Adjustment of a registration gap
- Display of filter information and reset timer
- Initialization of Cavity Security System (CSS)
- Content information display: title, aspect ratio, and KDM validity



Menu window of LKRA-003 Touch Panel Monitor (projectionist terminal)

Setup and Maintenance Functions by an SMS Control PC:

- Auditorium setup
- Log retrieval: including log filtering and secondary log distribution
- Interface (XML/HTTPS) to external Theater Management System (TMS)
- Automation system interface
- Security functions

Enclosure Status Light Management Functions:

- Monitors and aggregates status of all system components
- Sends aggregated status information to the status light of the enclosure

Theater Management System – STM-100



Menu windows of STM-100

The STM-100 Theater Management System (TMS) is one of the key digital cinema software applications that can provide efficient centralized management of theater operations – including schedule management, content data management, and status monitoring – allowing cinema complexes to streamline routine theater operations. The STM-100 provides the following range of functions:

Centralized Monitoring of Auditoriums Functions:

- Monitoring of auditorium and projector status
- Emergency operation of show (Stop, Pause, Resume, Resume with latency time)
- Display of auditorium details (Projector status, DCP ingest schedule, Show details, Error/Warning)
- Indication of status information such as fatal error/warning and creation/exporting of error logs

Schedule Management Functions:

- Daily and weekly schedule view with zoom function
- Import of schedule data from POS/Ticket system
- Automatic update of latest schedule from POS/Ticket system
- Automatic allocation of Show Play List (SPL) with POS schedule update
- Easy schedule creation by drag-and-drop operation
- Automatic creation of To-do List with priority (unassigned SPL, lack of DCP/KDM, etc) for schedule making

Creation of SPL Functions:

- SPL creation and management
- Composition Play List (CPL) grouping functions to combine multiple compositions (content programs such as trailers)
- Customized SPL template with Cue (output trigger)
- Blank time insertion into SPL
- Automatically adjustable cue setting
- Manual transfer of SPL to auditorium for test screening
- Content search/sort function with multiple parameters such as title and content group
- Flexible control of scheduled/manual payout

DCP/KDM Management Functions:

- Centralized DCP/KDM management and status monitoring
- Display of hierarchical DCP/KDM list with automatic linkage
- Display of urgent level for necessary DCP/KDM ingestion to local storage
- KDM validity status indication
- Display of capacity of central storage and local storage
- Automatic and manual ingest of DCP/KDM to auditorium
- Automatic and manual deletion of DCP/KDM
- Content transfer between multiple sources including library servers and local servers
- Management of multiple library servers within theater network

Other Valuable Features

- Interface with people directory systems
- Interface with external system via GPIO
- Management of third-party's servers under a single TMS

Dimensions

SRX-R320

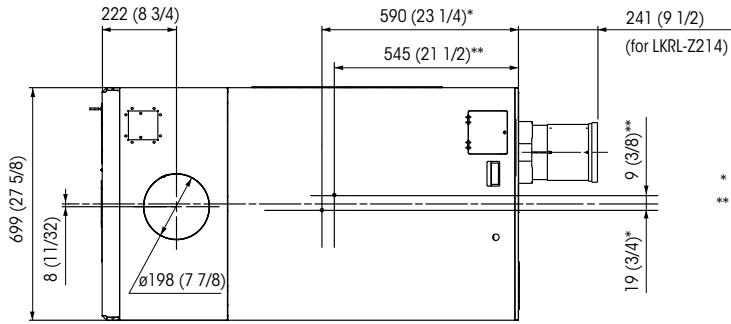

* Barycentric position of SRX-R320 with LKRL-Z214

** Barycentric position of SRX-R320 with LKRL-Z214 and LMT-300

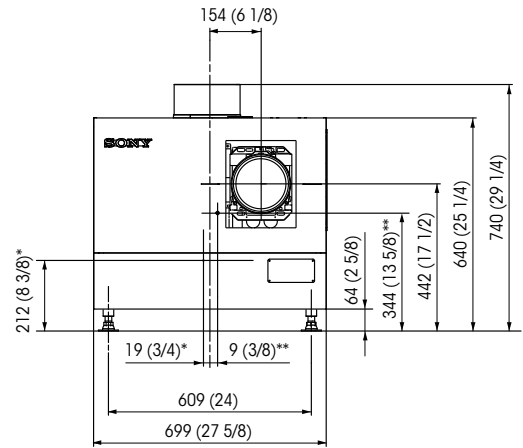
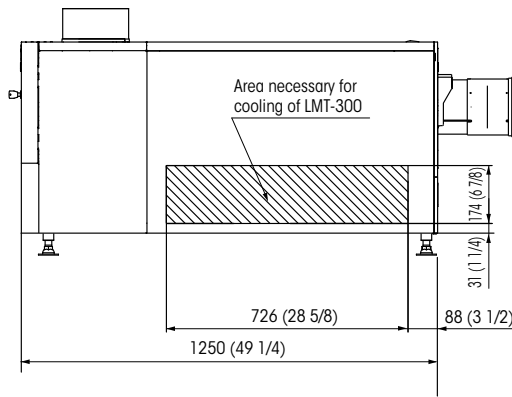

LMT-300

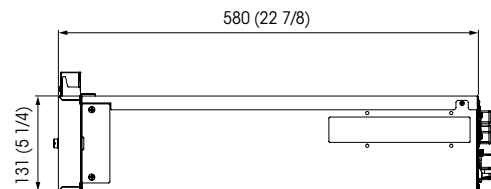
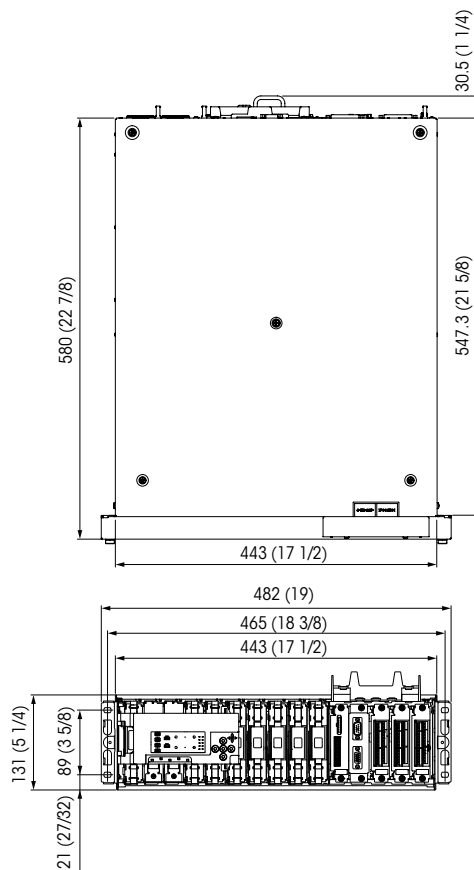

Unit: mm (inches)

Specifications of SRX-R320



SXRD Device Main Specifications

Display device	SXRD (Silicon X-tal Reflective Display)
Size	1.55-inch (diagonal)
Resolution	4096 (H) x 2160 (V) pixels
Contrast	More than 4000:1
Pixel pitch	8.5 μm
Width (between pixels)	0.35 μm
Response speed	2.5 ms (for both rise and fall)
Liquid crystal mode	Normally Black Mode
Alignment layer	Inorganic thin film
Liquid crystal cell gap	Less than 2 μm

Optical

Projection system	3-SXRD panel, prism color integrated system
Display device	SXRD, 1.55-inch (diagonal), 4096 (H) x 2160 (V) pixels on each chip
Lamp	4.2 kW Xenon lamp (x1), 3.0 kW Xenon lamp (x1), or 2.0 kW Xenon lamp (x1)
Contrast	More than 2000:1
Light output (average)	21000 lumens (center) (USHIO DXL-40SRX 4.2 kW lamp)

Signals

Media block input	4096 x 2160 pixels
HD-SDI/Dual-link HD-SDI*	1920 x 1080 pixels (SMPTE 372M/SMPTE 292M/ITU-R. BT709/BTA-S004), 12 bit/X'Y'Z' (Dual-link HD-SDI)
DC-SDI/Dual-link DC-SDI*	2048 x 1080 pixels at 23.98PsF/24PsF/24P, 12 bit/X'Y'Z' (Dual-link DC-SDI)
DVI-D	XGA (1024 x 768) at 60 FPS, HD (1280 x 720) at 50/60 FPS (HDCP), Quad-VGA (1280 x 960) at 60 FPS, SXGA (1280 x 1024) at 60 FPS, SXGA+ (1400 x 1050) at 60 FPS, UXGA (1600 x 1200) at 60 FPS, WUXGA (1920 x 1200) at 60 FPS, HD (1920 x 1080) at 24/50/60 FPS (HDCP), DC (2048 x 1080) at 24/48/60 FPS

Input/Output

Input A	DVI-D (HDCP)	
Input B	Open (option slot for the LKRI-003 or LKRI-005 board)	
Input C	A channel	MDR- 68-pin (x1) (for projector output A of Media Block, SRLV connection)
	B channel	MDR- 68-pin (x1) (for projector output B of Media Block, SRLV connection)
Remote interface		D-sub 15-pin (female) (x1), RS-232C
		RJ-45 (x1), 10BASE-T/100BASE-TX Ethernet
		DCP ingest port (x1)
Interlock		D-sub 15-pin (female) (x1), RS-232C
		For supply of power to an external ventilation fan and control of its operation

General

Power consumption	Max. 5.4 kW (4.2 kW lamp)
	Max. 4.2 kW (3.0 kW lamp)
	Max. 3.0 kW (2.0 kW lamp)
Power requirements	AC 200 V to 240 V, 50/60 Hz, single-phase, 27 A to 22.5 A
Operating temperature	5 °C to 35 °C (41 °F to 95 °F)
Operating humidity	35% to 85% (no condensation)
Storage temperature	-20 °C to +60 °C (12 °F to 140 °F)
Storage humidity	10% to 90%
Dimensions (W x H x D)	700 x 640 x 1250 mm (27 5/8 x 25 1/4 x 49 1/4 inches) (excluding a touch panel display and projecting parts of the unit such as a status light and a chimney)
Mass	195 kg (429 lb) (excluding an optional lamp and a lens)

Others

Colorimetry	Xenon color primaries		
	Encoding primaries	X	Y
	R	0.6800	0.3200
	G	0.2650	0.6900
	B	0.1500	0.0600
White reference	Xenon white reference		
		X	Y
	White reference	0.3140	0.3510
Safety regulations	[UL60950 listed], [cUL60950], [FCC Class A], [IC Class A], [VCCI Class A], [EN60950], [C-tick], [EN55022 Class A]		
Supplied accessories	Keys for removing panels (5), Keys for lamp replacement panel (2), Lens attachment screws (M8) (4), Status indicator lamp (1), TPC adaptor (1 set), One-touch bush (1), Attachment screws for status indicator lamp and TPC adaptor (1 set), Duct for LMT-300 (A) (1), Duct for LMT-300 (B) (1), LVDS cables (2), CSS cable (1), Ethernet cable (1), Operating instructions (1)		

* To support the HD-SDI/Dual-link HD-SDI or DC-SDI/Dual-link DC-SDI interfaces, the LKRI-003 Dual-link HD/DC-SDI Input Board is required. For information on using this board, please contact your nearest Sony office.

Specifications of LMT-300

General	
Power consumption	3.9 A to 1.7 A
Power requirements	AC 100 V to 240 V, 50/60 Hz
Operating temperature	5 °C to 35 °C (41 °F to 95 °F)
Operating humidity	35% to 85% (no condensation)
Storage temperature	-20 °C to +60 °C (-4 °F to 140 °F)
Dimensions (W x H x D)	443 x 131 x 580 mm (17 1/2 x 5 1/4 x 22 7/8 inches) (excluding projection parts)
Mass	25 kg (55 lb)

HDD	
Array composition	Data drive: 4 Parity drive: 2 Spare drive: 1 (hot swappable)
Record capacity	1.7 TB, Modified RAID 6

Video	
Projector output A	MDR 68-pin (x1) (for projector A channel, SRLV connection)
Projector output B	MDR 68-pin (x1) (for projector B channel, SRLV connection)
Compression format (decode)	JPEG 2000
Resolution	4K: 4096 (H) x 2160 (V) pixels, 2K: 2048 (H) x 1080 (V) pixels
Frame rate	2D: 4K at 24 FPS, 2K at 48 FPS, 2K at 24 FPS, 3D: 2K at 24 FPS

Audio	
Audio output 1	D-sub 25-pin (female) (x1), unbalanced, 8 channels
Audio output 2	D-sub 25-pin (female) (x1), AES/EBU, 16 channels (Pin assignment for Dolby option board 790)
Digital audio format	24 bits, 48/96 kHz, Linear PCM

Interface	
Network	RJ-45 (x3), DATA IN/CTRL IN/PRJ CTRL
CSS	HD D-sub 15-pin (female) (x1)
VGA	HD D-sub 15-pin (female) (x1) (for touch panel controller)
TPC	USB (x1)
Ingest port	USB (x1)
Spare I/2	USB (x2) (used for factory adjustment)
UPS control	D-sub 9-pin (female) (x1)
Audio control	D-sub 9-pin (male) (x1)
GPIO	GPIO board (x3) (GPI: 0 to 7, GPO: 0 to 15)
Status light	Special 8-pin connector (x1) (for signals), special 10-pin connector (x1) (for power supply)

Power Supply	
Redundant function*	Available by adding an optional second power supply unit to the LMT-300

* For detailed information, please contact your nearest Sony office.

Others	
Safety regulations	[UL60950 -1, CSA C22.2 No.60950.1], [FCC/IC EMC Class A Digital Device], [VCCI Class A], [EN60950-1], [EN50371], [EN55022/Class A], [EN55024 (ITE)], [EN61000-3-2], [61000-3-3], [IEC60950-1], [AS/NZS CISPR22 (EN55022) Class A], [JIS C 61000-3-2]
Supplied accessories	Screw (4), D-sub 9-pin connecting cable (3 m) (1), Terminal board (socket) 10-pin (1), Operating instructions (1)



Front panel



Front view without front panel



Rear panel

Table of Available Lenses

	LKRL-Z211		LKRL-Z214		LKRL-Z219	
	Wide	Tele	Wide	Tele	Wide	Tele
Zoom Ratio	1.67x		1.78x		2.16x	
Throw ratio*	1.05:1 to 1.75:1		1.35:1 to 2.40:1		1.85:1 to 4.00:1	
F-number	2.8		2.8		2.8	
Screen width	Throwing Distance		Throwing Distance		Throwing Distance	
4,500 (177 5/32)	4,620 (181 7/8)	8,017 (315 5/8)	5,986 (235 21/32)	10,851 (427 3/16)	8,114 (319 7/16)	18,252 (718 19/32)
5,000 (196 27/32)	5,148 (202 21/32)	8,921 (351 7/32)	6,665 (262 13/32)	12,071 (475 7/32)	9,037 (355 25/32)	20,330 (800 13/32)
6,000 (236 7/32)	6,203 (244 7/32)	10,730 (422 7/16)	8,025 (315 15/16)	14,510 (571 9/32)	10,882 (428 13/32)	24,486 (964 1/32)
7,000 (275 19/32)	7,259 (285 25/32)	12,539 (493 21/32)	9,384 (369 7/16)	16,950 (667 11/32)	12,727 (501 1/32)	28,642 (1,127 21/32)
8,000 (314 31/32)	8,314 (327 11/32)	14,348 (564 7/8)	10,743 (422 31/32)	19,390 (763 3/8)	14,572 (573 11/16)	32,798 (1,291 9/32)
9,000 (354 11/32)	9,370 (368 29/32)	16,157 (636 1/8)	12,102 (476 15/32)	21,830 (859 7/16)	16,417 (646 5/16)	36,954 (1,454 29/32)
10,000 (393 11/16)	10,426 (410 15/32)	17,966 (707 11/32)	13,461 (529 31/32)	24,270 (955 1/2)	18,261 (718 31/32)	41,110 (1,618 17/32)
12,000 (472 7/16)	12,537 (493 9/16)	21,584 (849 25/32)	16,180 (637)	29,149 (1,147 19/32)	21,951 (864 7/32)	49,422 (1,945 25/32)
14,000 (551 3/16)	14,648 (576 11/16)	25,202 (992 7/32)	18,898 (744 1/32)	34,029 (1,339 23/32)	25,641 (1,009 1/2)	57,735 (2,273 1/32)
16,000 (629 29/32)	16,759 (659 13/16)	28,820 (1,134 21/32)	21,617 (851 1/16)	38,908 (1,531 13/16)	29,331 (1,154 25/32)	66,047 (2,600 9/32)

* Distance between the center of the projector lens and the screen, divided by the screen width.

Unit: mm (inches)

Optional Accessories



LKRA-003
Touch Panel Monitor

* For information on availability, please contact your nearest Sony office.



LKRL-Z211
Zoom Lens
Throw ratio*: 1.05:1 to 1.75:1

* The throw ratio denotes the ratio that the projection distance is divided by the screen width.



LKRL-Z214
Zoom Lens
Throw ratio: 1.35:1 to 2.40:1



LKRL-Z219
Zoom Lens
Throw ratio: 1.85:1 to 4.00:1



LKRL-A001
Anamorphic Lens with
Lens Changer Unit



LKRL-A002/LKRL-A003
3D Projection Lens Unit
Throw ratio of LKRL-A002:
1.1 to 1.9 (side mask),
1.4 to 2.5 (top-bottom mask)
Throw ratio of LKRL-A003:
1.9 to 4.0 (side mask),
2.5 to 5.0 (top-bottom mask)

* For information on using the LKRL-A002/ LKRL-A003, please contact your nearest Sony office.

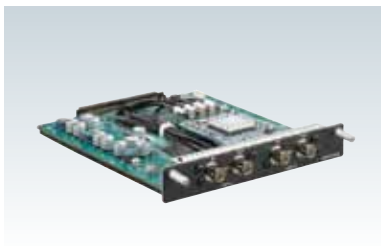

LKRI-003
Dual-link HD/DC-SDI Input Board

* For information on using the LKRI-003 board, please contact your nearest Sony office.

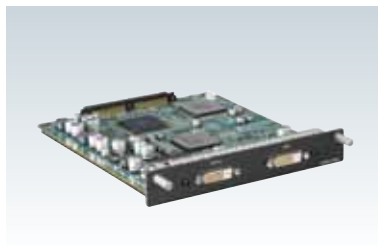

LKRI-005
DVI (HDCP) Input Board

* For information on using the LKRI-005 board, please contact your nearest Sony office.

Distributed by

©2011 Sony Corporation. All rights reserved.

Reproduction in whole or in part without permission is prohibited. Features and specifications are subject to change without notice.

The values for mass and dimension are approximate.

Sony is a registered trademark of Sony Corporation.

"Sony Digital Cinema", "Sony Digital Cinema" 4K logo, "Sony Digital Cinema" 3D logo, "SXR" and "SXR" logo are trademarks of Sony Corporation.

Microsoft and Windows are registered trademarks of Microsoft Corporation.

VistaVision is a registered trademark of Paramount Pictures Corporation.

CinemaScope is a registered trademark of

20th Century Fox Film Corporation.

Dolby is a registered trademark of Dolby Laboratories.

All other trademarks are property of their respective owners.

