

SONY
make.believe

XDS-PD2000
XDS-PD1000
XDS-1000
XDCAM Station

XDCAM

MPEG HD422



XDCAM

MPEG HD422

SXS

Professional Disc™
DL

Professional Disc™
XL-QD

The XDCAM Professional Media Station for a Unique Hybrid Workflow and Wide Range of Multi-tasking Operations.

Since introducing XDCAM Professional Disc products in 2003, Sony has been supporting smooth migration from tape to tapeless with user-friendly file-based operations. To accelerate operational efficiency, Sony introduced the revolutionary XDCAM EX camcorder with SxS memory cards in 2007. Like the XDCAM Professional Disc products, this new camcorder series adopted MPEG2 Long GOP compression technology.

Now, to meet a broad variety of customer applications needs, Sony has established a unique hybrid workflow featuring these different media - Professional Disc and SxS card - that share the same compression technology. Sony proudly introduces a powerful new XDCAM family member, the XDCAM Professional Media Station (XDCAM Station) providing a "bridge solution" between Professional Disc and SxS card, and featuring large-capacity internal storage (HDD or SSD).

By supporting this range of recording media, the XDCAM Station realizes a flexible hybrid workflow and enables high-performance multi-tasking operations. It has the characteristics both of a utility deck, with VTR-like user-interface, and of a high-performance server system in one single unit.



<p>High Picture Quality MPEG2 Long, HD422 50Mbps 1920x1080, 1280x720 Full HD</p>	<p>Hybrid Media Workflow Professional Disc, SxS Memory Card, Internal Storage</p>
<p>XDCAM</p>	
<p>IT Friendly High Performance Network, Open Standard Protocol</p>	<p>Server Operation Multi-Task, Multi-Access, Chase Play, Stream Chase</p>

Product Lineup



XDS-PD2000



- Internal Storage : SSD (0.5 TB)
- Hybrid Operation of Disc and Memory
- NLE Direct Access and Multi-tasking
- Top-end Model with Higher Performance



XDS-PD1000



- Internal Storage : HDD (1 TB)
- Hybrid Operation of Disc and Memory
- Long Duration Recording on Internal HDD
- Cost-effective Multi-Media Model



XDS-1000



- Internal Storage : HDD (1 TB)
- Long Duration Recording on Internal HDD
- High-speed Back-up Copy from Memory
- Memory Camcorder Companion

* The XDS-PD1000 and XDS-PD2000 will be available in mid-2011.

MAIN FEATURES

- XDCAM Format, MPEG2 Long GOP
- SD/HD Recording (HD422, HD420, IMX, DVCAM)
- Multi-media (Disc/Memory/Internal Storage)
- High-speed Inter-media Copy
- Long Duration Recording of Line Feed
- Variety of Multi-tasking Operations
- NLE Direct Access Via Gigabit Ethernet (CIFS)
- Multiple Stream Access for NLE and Server
- Stream Chase Edit and File Transfer
- Open-standard Network Protocol Support
- High Reliability and Robustness
- VTR-like User-friendly Interface
- HD-SDI In/Out (1-in/1-out), DVB-ASI IN/OUT (Option)



RECORDING MEDIA AND FORMAT

Multi-media In one Unit

The XDCAM Professional Media Station supports three types of media-storage, Professional Disc, SxS memory card, and internal storage with HDD or SSD (solid-state device).



Support for Quad-layer Disc (128 G, Write-once)

The XDS-PD1000 and XDS-PD2000 adopt a new generation of Professional Disc drive, called the "Dual Channel Head System". This new drive provides high-speed read-out and quad layer disc (128 G) support. Single-layer (23 G) and dual-layer (50 G) discs also supported. The 128 G Professional disc has a recording duration of 4 hours with 50Mbps files. This write-once disc prevents precious contents from being altered and is suitable for deep archiving.

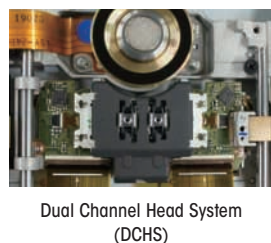

Recording Format

The internal storage supports the MXF format and MPEG2 Long GOP compression, the same as XDCAM Professional Discs. HD422 50 Mbps recording provides 1920 x1080 and 1280 x720 resolution, and uncompressed 8-channel 24-bit /48kHz linear PCM audio. MPEG HD420 35 Mbps, IMX 50 Mbps and DVCAM 25 Mbps are also supported.

* For details of recording and playback formats, please refer to the specification table on the last page.



Choice of Internal Storage with HDD and SSD

The XDS-1000 and XDS-PD1000 have Internal HDD (1 TB) which allows recording line feed signal for approx. 30 hours with 50 Mbps clips. This is very useful for camera ISO recording at outside events and inside studios. The XDS-PD2000 is equipped with SSD (0.5 TB) and can record approx. 16 hours with 50 Mbps clips. The SSD delivers much higher performance for multi-tasking and multi-access operations.

HIGH PERFORMANCE AND VARIOUS FEATURES

High-speed Back-up Copy

Any content fully stored on Disc or SxS card can be copied to internal storage very rapidly (called "Inter-media Copy"). The transfer speed is approximately 10 times faster than real time for SxS card, 5 times faster for disc. MP4 files on SxS card are converted to MXF when copied to internal storage. After copying, the media can be reused in the camcorders.

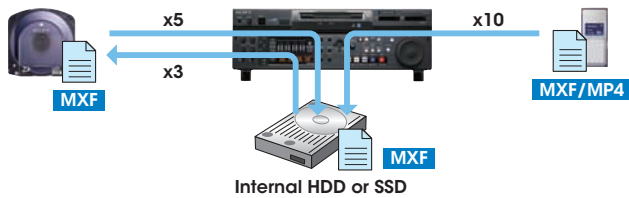

Open-standard, VDCP, FTP, CIFS, and GPIO

Many open-standard protocols are supported. VDCP is for automation control, switchers and replay controllers. FTP and CIFS are network protocols: FTP is for file transfer, and CIFS for direct access from NLEs. And the XDCAM Station can be controlled remotely through Ethernet, using the XDCAM Browser. "REC" "PLAY" and "STOP" can be performed via the network. The remote control using API and WebService(SOAP) via ethernet are supported. In addition, the conventional Sony 9pin VTR protocol and GPIO are available.

High-quality Slow-motion and Highlight Replay

By connecting to a slow-motion and replay controller through VDCP, the XDCAM Station can provide slow-motion and highlight replay capabilities with a high picture quality. Sony offers a simple and affordable slow-motion solution.

Up/Down- and Cross-conversion

The XDCAM Station supports HD and SD as standard. And a powerful up/down- and cross-conversion system provides great operational flexibility.

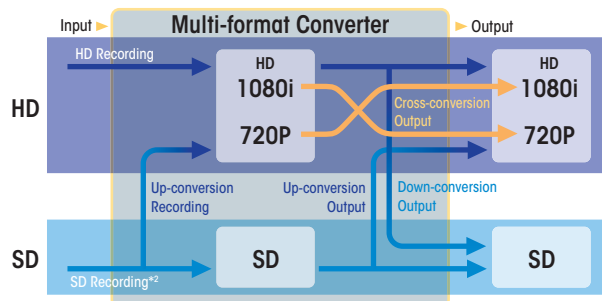

Wide Range of Multi-tasking Operations

Utilizing the high-performance internal storage, it is possible to access a newly created file while it is being recorded. While the user is recording the line feed input signal (HD-SDI/SD-SDI/DVB-ASI), the new clip can be played back (called "Play while Recording"). Also while recording, the file can be accessed from NLEs (called "Edit while Recording"), or the file can be transferred to other servers. While recording or playback clips on the internal storage, the Inter media copy can be made at the same time. The user can make a backup copy from Professional Disc or SxS card to internal storage without affecting REC/PLAY operation.

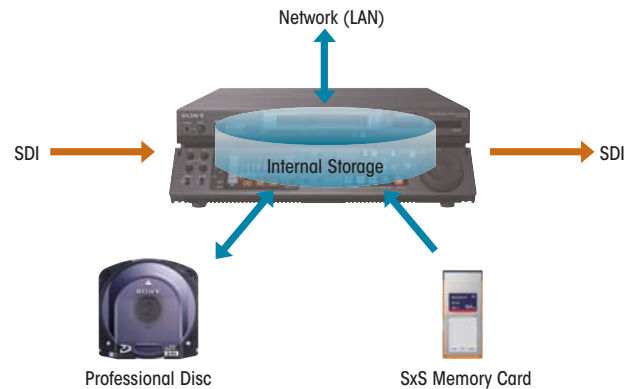

Multiple Stream Access via GigE

Thanks to the high network connectivity and efficient codec of MPEG2 Long GOP, multiple NLEs can have concurrent access. The XDS-PD2000 (SSD model) supports 6-stream access of 50 Mbps files, while maintaining base-band recording and playback.

NLE Direct Access with Internal SSD

A non-linear editor can directly access internal SSD storage content through the GigE network. This allows the user to start editing immediately.

* The XDS-1000 and XDS-PD1000 (HDD models) also support direct access, but throughput is limited by HDD bandwidth.

Stream Chase Edit and File transfer

NLEs can access newly recorded file as it is growing in internal storage. Every time the user access the growing file, they receive the most up-to-date scene. Also a growing file can be transferred to other servers (called "Stream Chase"), a feature which can drastically improve operations with no waiting time.

USER-FRIENDLY CONTROL AND HIGH RELIABILITY

User-friendly Front Panel Control

The VTR-like front panel allows you to control the Professional Disc drive, SxS memory card slots and internal storage, separately. A Jog/Shuttle dial makes for a very smooth motion picture. In the event of network trouble, users can play out a video program from Professional Disc directly, via front panel operation in Local mode.



RAID-4 Storage and Redundant Power

The XDS-1000 and XDS-PD1000 (HDD models) have the RAID-4 system as standard. Even if one HDD fails, operation continues without interruption. The XDS-PD2000 has built-in SSD, which provides excellent performance in the event of shock and vibration. There is an optional XDBK-102 RAID unit for the SSD. XDBK-101 is optional redundant power supply unit for all models of XDCAM Station.

Low Power, Silent Operation and Reliable

The XDCAM Professional Media Station has a Sony-dedicated hardware design and using Linux OS. The unit offers low power consumption and silent operation, ideal for office and control room environments. It also offers fast start-up and safety shut-down times, and deliver far higher performance and reliability than PC servers.

Rear Panel (XDS-PD2000/PD1000/1000)



XDCAM Browser

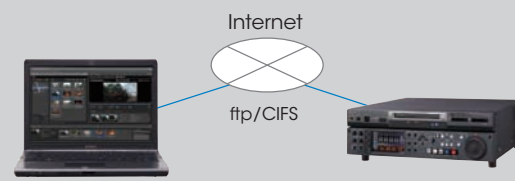

- File Management and Thumbnail Browsing
- Inter-media Clip Copy (Drag & Drop)
- Remote Control Via Network (API)

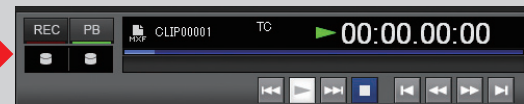

APPLICATIONS

Application-1 : OB VAN (SNG)

The "Server" and "Back-up deck" are combined in one unit. Multi-media and multi-tasking capabilities create superb efficiency in a small space. From acquisition to backup, and transmission to archive, there's XDCAM end-to-end file-based workflow, along with the high reliability of Professional Disc media and Sony's hardware.

< Workflow >

- 1 Camera line feed (ISO) recording for about 30 hours of 50 Mbps clips on internal HDD. (*XDS-1000 & XDS-PD1000)
- 2 Media backup copy from Professional Disc or SxS card to internal storage while recording line feed.
- 3 A new clip in internal storage can be copied to a large capacity disc (128 GB) while recording the line feed.
- 4 Check contents on the XDCAM Browser or front panel; any clips can be played back while recording.
- 5 DVB-ASI input/output (option) can transmit high-quality HD video with 4ch audio and metadata via Satellite.

Advantages

- Multi-media in small space
- Long duration recording
- High-speed inter-media copy
- Backup to Professional Disc
- Playback while recording
- Backup while recording
- High reliability

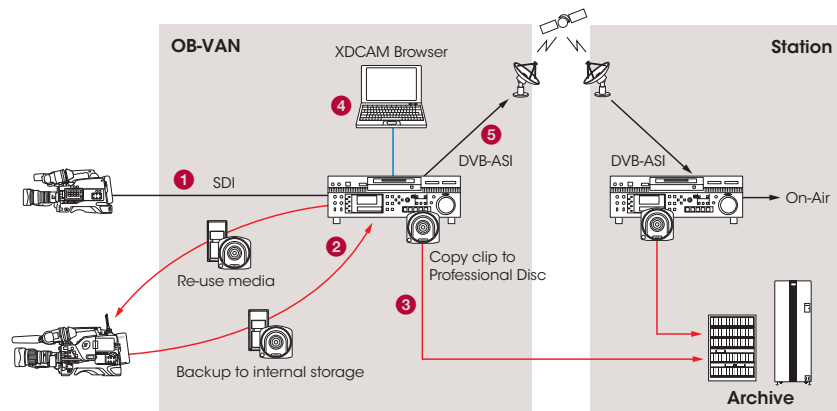

Application-2 : Studio Ingest and Editing/File Transfer

SSD internal storage offers higher level multi-access, multi-tasking performance, in conjunction with high-efficiency MPEG2 Long 50 Mbps compression files and GigE high-speed network capabilities. Gain immediate access to growing files; no need to wait for the recording or ingest to end. The process is simple fast and comfortable.

< Workflow >

- 1 Studio camera line feed (ISO) recording up to about 16 hours of 50 Mbps clips on internal SSD. (*XDS-PD2000)
- 2 Media ingest (Professional Disc or SxS card) can be made while recording line feed.
- 3 NLE direct access to the new clip (the growing file) in SSD while recording (Stream Chase Edit).
- 4 The growing file can be transferred to other servers while recording the line feed (Stream Chase Transfer).
- 5 The new clip can be played back for review or fed to a linear edit recorder while recording continues.
- 6 The new clip in internal storage can be copied to a large capacity disc (128 GB) while recording the line feed.

* The performance of line feed recording and base-band playout are guaranteed, separate from file access and inter-media copy operations.

Advantages

- Long duration recording
- Growing file transfer to server
- NLE direct access
- Playback while recording
- NLE access while recording (Stream Chase Edit)
- High-speed inter-media copy
- Backup to Professional Disc
- Easy operation from front panel

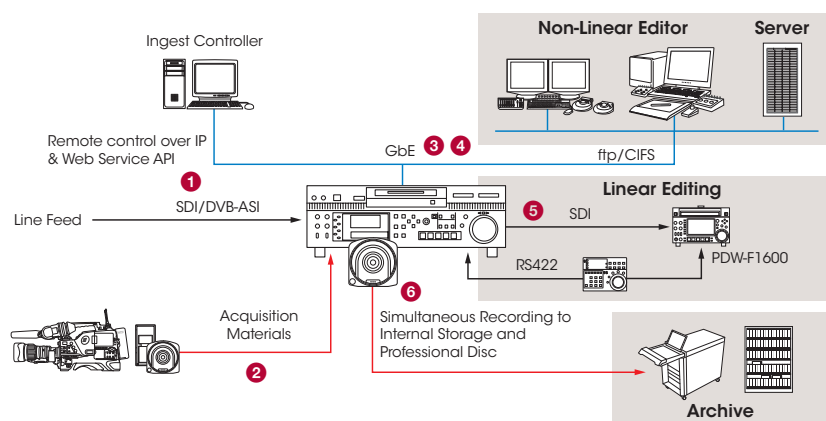

Application-3 : Sports/Live Production

This provides an affordable slow-motion and highlight replay solution with high picture quality (XDCAM HD422 50 Mbps). Key functions include Playback while Recording, and Media Ingest and Media Backup while Recording. In short, this solution is simple and flexible. All footage from camera ISO recording can be carried on Professional Disc to the production house or broadcast station - it's that easy!

< Workflow >

- 1 Studio camera line feed (ISO) recording for about 30 hours on internal HDD. (*XDS-1000 & XDS-PD1000)
- 2 Media ingest while recording (eg. pre-game footage from SxS card and archive game footage from Professional Disc).
- 3 3rd party controller connected via VDCP can simply provide slow-motion and highlight replay.
- 4 The new clip in internal storage can be copied to a large capacity disc (128 GB) while recording the line feed.
- 5 Users can make direct access or ftp for NLE editing through GigE while recording and playback continue.
- 6 Use the XDCAM Browser for file transfer, clip title and metadata entries, clip browsing, and remote control of the XDCAM Station via GigE network.

Advantages

- Affordable slow-motion solution
- Long duration recording
- Playback while recording
- NLE access while recording (Stream Chase Edit)
- Backup to Professional Disc

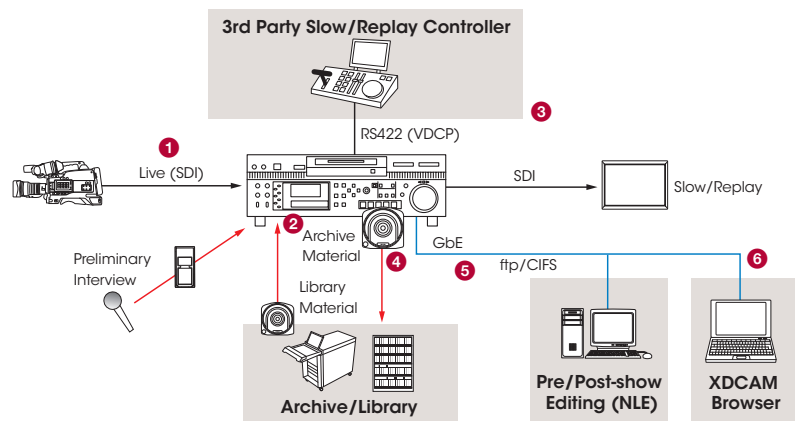

Application-4 : Playout

The "Playout server" and "Emergency playout deck" are combined in one unit. The XDCAM Station has a variety of ingest styles according to network, media and base-band (SDI). It also offers various playout control styles via VDCP and the simple front panel. With easy and secure operation with Professional Disc and front-panel control, the XDCAM station can be used as a very reliable backup system.

< Workflow >

- 1 Program materials can be ingested to internal storage via base-band (SDI), media or network.
- 2 Play out the clips via front panel control or a VDCP playout controller
- 3 Last minute changes can be made to program clips by ingesting through Professional Disc.
- 4 In the event of network trouble, material can be played out from Professional Disc directly via front panel operation.

Advantages

- Easy integration via VDCP
- Flexible ingest styles
- Reliable operation in an emergency
- Easy operation from front panel
- High reliability with a redundant power supply and RAID-4 storage

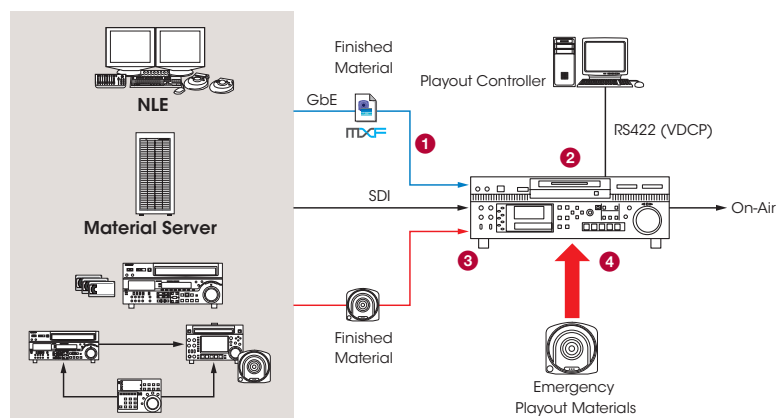

ACCESSORIES

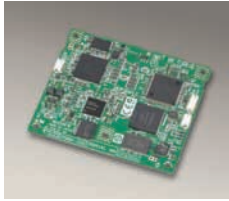

PDBK-202
MPEG TS IN/OUT Board
(DVB-ASI In/Out)



XDBK-101
Redundant Power Supply



XDBK-102
SSD Drive for RAID-4 System
(for XDS-PD2000)

SPECIFICATIONS

	XDS-PD2000	XDS-PD1000	XDS-1000
General			
Power requirements	AC 100 V to 240 V, 50/60 Hz		
Power consumption	210 W	190 W	170 W
Operating temperature	5°C to 40°C (+41°F to 104°F)		
Storage temperature	-20°C to +60°C (-4°F to +140°F)		
Humidity	25% to 90% (relative humidity)		
Mass	1.6 kg (35 lb 9 oz)	1.7 kg (37 lb 8 oz)	1.5 kg (34 lb 2 oz)
Dimensions (W x H x D) (excluding protrusions)	424 x 132 x 460 mm (16 3/4 x 5 1/4 x 18 1/8 inches)		
Recording/Playback format (Video)	MPEG HD422 (CBR: 50 Mbps) MPEG HD: HQ mode (VBR, maximum bit rate: 35 Mbps), SP mode* (CBR, 25 Mbps), LP mode* (VBR, maximum bit rate: 18 Mbps), MPEG IMX (CBR, 50/40*/30* Mbps) DVCAM (CBR, 25 Mbps) * Playback/Copy only		
Recording/Playback format (Audio)	MPEG HD422: 8 ch/24 bits/48 kHz MPEG HD: 4 ch/16 bits/48 kHz MPEG IMX: 4 ch/24 bits/48 kHz or 8 ch/16 bits/48 kHz DVCAM: 4 ch/16 bits/48 kHz		
Recording/Playback format (Proxy Video)	MPEG-4		
Recording/Playback format (Proxy Audio)	A-law (8 ch/8 bits/8 kHz)		
Recording/Playback time	[Internal Storage] MPEG HD422: 50Mbps: Approx. 1.6 hour MPEG HD: 35 Mbps, 4-ch audio: More than 24 hour 35 Mbps, 2-ch audio: More than 25 hour * 25 Mbps, 4-ch audio: Approx. 31 hour * 25 Mbps, 2-ch audio: Approx. 33 hour * 18 Mbps, 4-ch audio: More than 41 hour * 18 Mbps, 2-ch audio: More than 44 hour * MPEG IMX: 50 Mbps: Approx. 1.6 hour 40 Mbps: Approx. 2.0 hour * 30 Mbps: Approx. 2.5 hour * DVCAM: 25 Mbps: Approx. 3.0 hour * Playback/Copy only	[Internal Storage] MPEG HD422: 50Mbps: Approx. 3.0 hour MPEG HD: 35 Mbps, 4-ch audio: More than 48 hour 35 Mbps, 2-ch audio: More than 50 hour * 25 Mbps, 4-ch audio: Approx. 6.3 hour * 25 Mbps, 2-ch audio: Approx. 6.6 hour * 18 Mbps, 4-ch audio: More than 8.2 hour * 18 Mbps, 2-ch audio: More than 8.8 hour * MPEG IMX: 50 Mbps: Approx. 3.3 hour 40 Mbps: Approx. 4.0 hour * 30 Mbps: Approx. 5.0 hour * DVCAM: 25 Mbps: Approx. 6.1 hour * Playback/Copy only	
Search speed range (Shuttle mode)	-20 times to +20 times normal speed		
Search speed range (Variable mode)	-2 times to +2 times normal speed		
Search speed range (Jog mode)	-1 time to +1 time normal speed		
Search speed range (F.Fwd/Rev)	-35/+35 times normal speed		
Internal Storage			
Storage Type	SSD, SATA, 256GB	HDD, SATA, 500GB	
Number of Drive Unit	2 (max 3)	3	
Total Capacity (Data Area)	512GB	1TB	
Raid	Raid-4 (Option)	Raid-4	

	XDS-PD2000	XDS-PD1000	XDS-1000
Inputs/Outputs			
Reference input	BNC (x2) (including loop-through), HD Tri-level sync (0.6 Vp-p/75 Ω/negative) or SD blackburst/composite sync (0.286 Vp-p/75 Ω/negative)		
HD/SD-SDI input	BNC (x1) (HD/SD/DVB-ASI (option) switchover) HD-SDI: SMPTE 292M (w/embedded audio) SD-SDI: SMPTE 259M (w/embedded audio)		
Analog audio input	XLR-type 3-pin (female) (x2), +4/0/-3/-6 dBu (selectable), 10 kΩ, balanced		
Digital audio input (AES/EBU)	BNC (x4), 8 ch (2 ch each, 1/2 ch, 3/4 ch, 5/6 ch and 7/8 ch), AES-3id-1995		
Time code input	BNC (x1), SMPTE time code, 0.5 Vp-p to 1.8 Vp-p/10 kΩ/unbalanced		
System time code input	BNC (x1), SMPTE time code, 0.5 Vp-p to 1.8 Vp-p/10 kΩ/unbalanced		
HD-SDI output	BNC (x2), 1: SMPTE 292M (w/embedded audio), character On/Off 2: SMPTE 259M (w/embedded audio), character On/Off		
SD-SDI output	BNC (x2), 1: SMPTE 259M (w/embedded audio) 2: SMPTE 259M (w/embedded audio), character On/Off		
Analog composite output	BNC (x1), 1.0 Vp-p/75 Ω/negative, SMPTE 170M		
HD-SDI monitor output	BNC (x1), SMPTE 292M (w/embedded audio), character On/Off		
SD-SDI monitor output	BNC (x1), SMPTE 259M (w/embedded audio), character On/Off		
DVB-ASI output	BNC (x1)		
Analog composite monitor output	BNC (x1), 1.0 Vp-p/75 Ω/negative, SMPTE 170M, character On/Off		
HDMI monitor output	Type A 19-pin (x1)		
Monitor	DE-15 (x1), (VGA)		
Analog audio output	XLR-type 3-pin (male) (x2) (channel selectable), +4/0/-3/-6 dBu (selectable), 600 Ω, Lo-Z, balanced		
Analog audio monitor	XLR-type 3-pin (male) (x2), +4 dBu, 600 Ω, Lo-Z, balanced		
Digital audio output (AES/EBU)	BNC (x4), 8 ch (2 ch each, 1/2 ch, 3/4 ch, 5/6 ch and 7/8 ch), AES-3id-1995		
Headphone output	JM-60 Stereo phone jack (x1), ∞ - -13 dBu, 8 Ω, unbalanced		
Time code output	BNC (x1), SMPTE time code, 1.0 Vp-p/75 Ω/unbalanced		
Video control	D-sub 9-pin (female) (x1), EIA RS-423		
Ethernet	RJ-45 (x1), 1000BASE-T, IEEE802.3ab, 100BASE-TX, IEEE802.3u, 10BASE-T, IEEE802.3		
USB	Hi-Speed USB (USB 2.0) (Front x1, Rear x4)		
Remote (9P) input	D-sub 9-pin (female) (x2), RS-422A		
GPIO	D-sub 15-pin (female) (x1), Input: CMOS, Output: open-collector		
AC input	(x1), 100 V to 240 V, 50/60Hz		
Video Performance			
Sampling frequency	Y: 74.25 MHz, Pb/Pr: 37.125MHz		
Quantization	8 bits/sample		
Error correction	Reed Solomon Code		
Processor Adjustment Range			
Video level	∞ to +3 dB		
Chroma level	∞ to +3 dB		
Set up/black level	± 30 IRE/±210 mV		
Chroma phase	±30°		
System sync phase	±15 μs		
System SC phase	0 ns to 400 ns		
Audio Performance			
Sampling frequency	48 kHz		
Quantization	24 bits		
Frequency response	20 Hz to 20 kHz +0.5/-1.0 dB (0 dB at 1 kHz)		
Dynamic range	More than 90 dB		
Distortion	Less than 0.05% (at 1 kHz)		
Headroom	-20/-18/-16/-12/-9 (EBUL) dB (selectable)		
Others			
Built-in display	4.3-inch type color LCD monitor		
Expansion Slot	8x PCI Express (x2 slot)		

The XDS-1000, XDS-PD1000, and XDS-PD2000 are produced at Sony EMCS Corporation Kosal Tec, which has received ISO14001, the Environmental Management System Certification.



Distributed by

©2011 Sony Electronics Asia Pacific Pte. Ltd. All rights reserved. Reproduction in whole or in part without written permissions is prohibited. Features, design and specifications are subject to change without notice. The values for mass and dimension are approximate. "Sony", "make.believe", "XDCAM", "Professional Disc", "XDCAM EX", "SxS", "MPEG IMX" and "DVCAM" are trademarks of Sony Corporation. All other trademarks are the property of their respective owners.

This brochure refers to software or products designed for use with an MS Windows® operating system (OS). U.S. export control regulations may require an export license for export/re-export of the Windows OS (for details, contact Microsoft Corporation).

pro.sony-asia.com/broadcast