

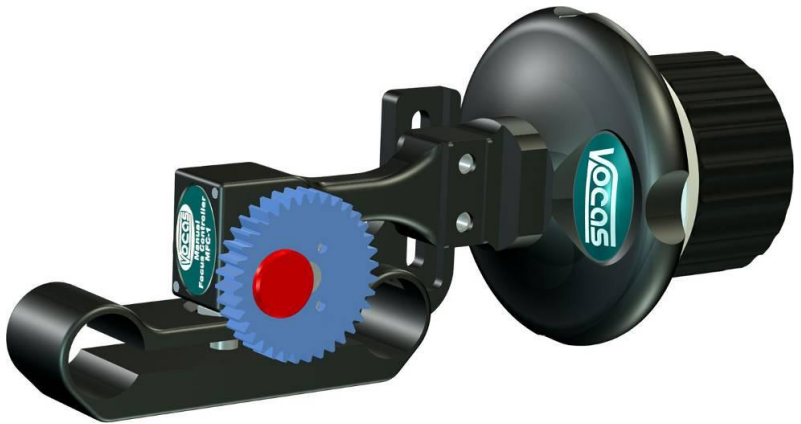

User manual
Follow Focus MFC-1
Version 2.0.1



Index:

Box contents Manual Focus Controller #0500-0001:	3
Guide to components, Manual Focus controller #0500-0001:.....	3
Common directions for mounting:.....	4
Recommended mounting positions:	5
Height adjustment:.....	6
Adjusting the rotation lock:.....	7
Accessories:.....	8
Contact data:.....	8

Box contents Manual Focus Controller #0500-0001:

- 1 Manual Focus Controller.
- This manual.
- 1 replaceable scale

Guide to components, Manual Focus controller #0500-0001:

Front view

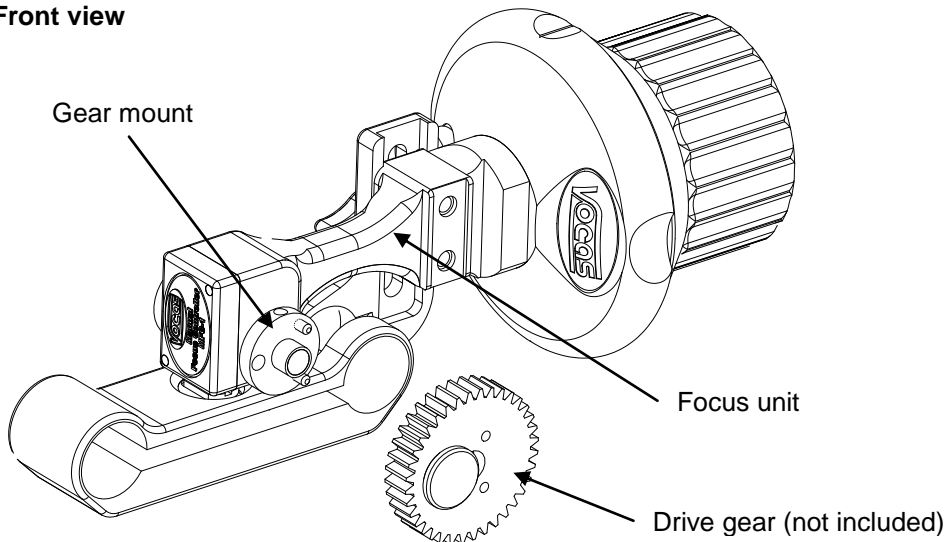

Rear view

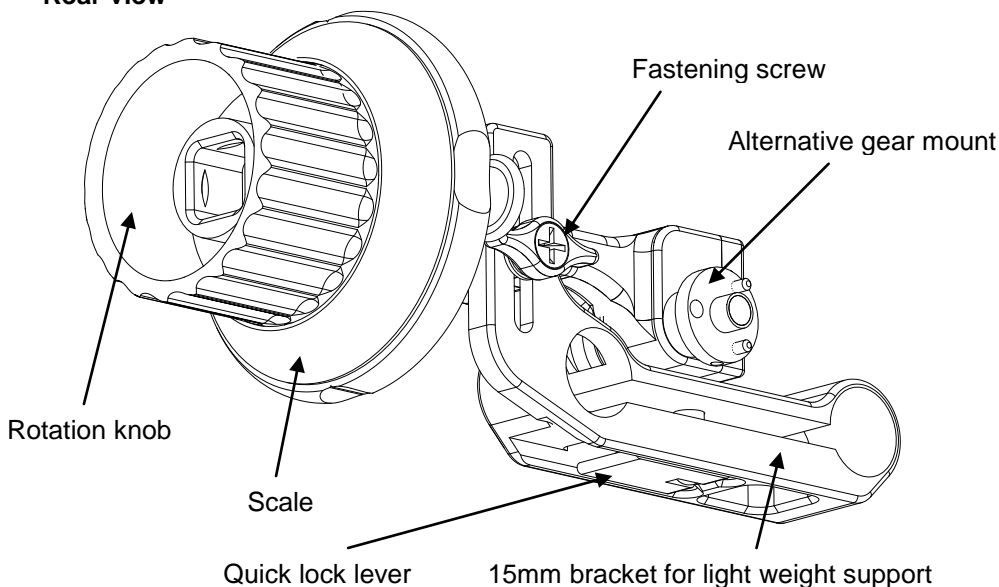

Common directions for mounting:

The MFC-1 can be attached to the camera in multiple ways. (Depending on what camera and lens you use, you may want to use a different configuration):

- First of all, the Focus Unit can be attached to the 15mm bracket in two ways. The Gear mount is offset in relation to the rotation knob, so the Focus unit can be mounted in a “high” or a “low” configuration. **Be aware:** the rotation direction of the drive gear will change when doing so. It works as follows:
 1. Unscrew the Fastening screw to release the Focus unit.
 2. Remove the Focus unit from the 15mm bracket.
 3. Rotate the Focus unit 180 degrees.
 4. Reattach the Focus unit to the 15mm bracket using the Fastening screw.

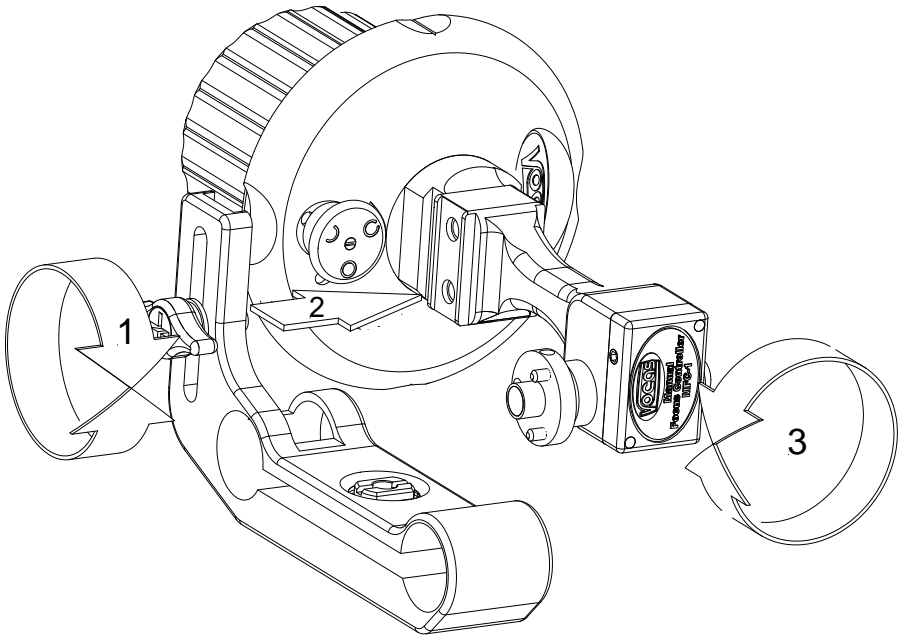

- Secondly, the Drive gear can be mounted on either side of the Focus unit. There are two linked Gear mounts, which can be used. Depending on where the gear ring is located on the camera lens, you may want to change which Gear mount you use.
- Alternatively you can mount the entire MFC-1 backwards on the 15mm bars, so the Rotation knob can be used with the right hand.

Recommended mounting positions:

Position 1

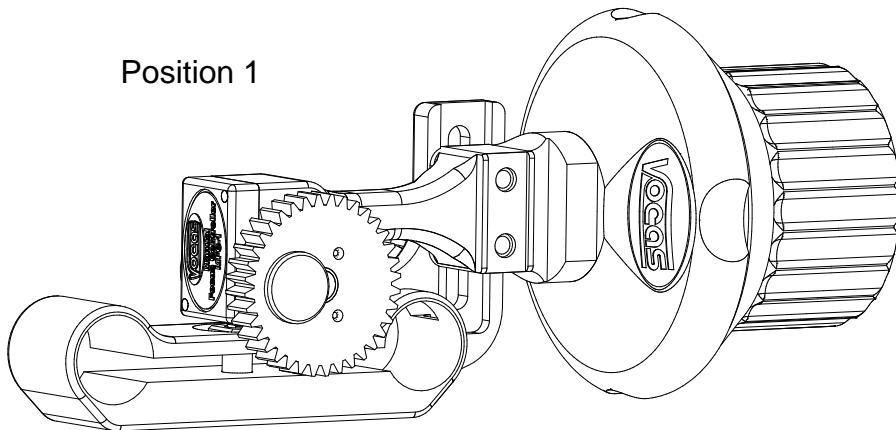

This position is recommended for the following cameras.

- Sony HVR-Z1/ HDR-FX1 (HDV).
- Panasonic DVX-100(A).
- Panasonic HVX-200.
- Canon XL-1(S) / XL-2 / XL-H1 & 16X / 20X / 3X org. lens.
- Canon XL-1(S) / XL-2 / XL-H1 & 16X / 14X man. lens.

Position 2

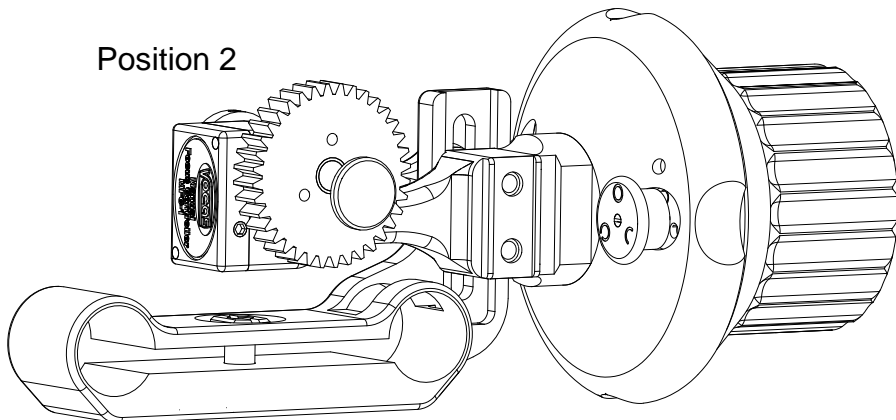

This position is recommended for the following cameras:

- JVC GY-HD100 & Fujinon org. lens.
- Almost every broadcast lens.

Height adjustment:

Once you've determined the ideal mounting position of the MFC-1 the height will have to be adjusted, so the drive-gear can make contact with the gear-ring on the lens. This works as follows:

1. Loosen the Fastening screw. This will unlock the Focus Unit and allow it to slide up or down.
2. Move the Focus unit up or down so that the drive-gear fits snugly into the gearing on the lens. **Warning: do not use force while placing the drive gear into the gear ring. Doing so may damage your lens and will adversely effect the functioning of the follow focus.**

(Tip: for optimum functioning of the follow focus, hold the camera upside-down, and let the weight of the follow focus press the drive gear into the gear ring. This will often result in the optimal functioning of the follow focus.)

3. Tighten the fastening screw, locking the Focus unit into place. The MFC-1 should now be ready for use.

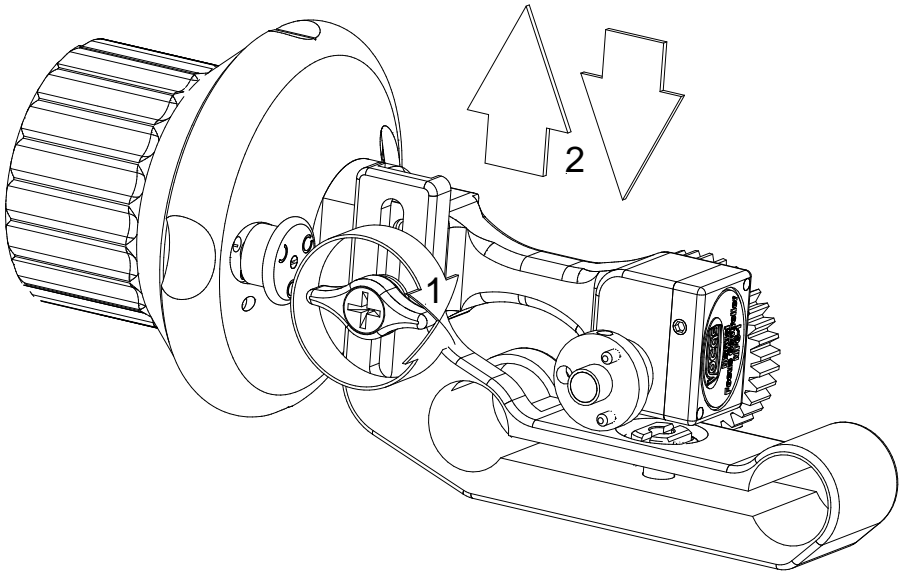

Adjusting the rotation lock:

The MFC-1 is equipped with an internal “rotation stop” that can be enabled or disabled whenever the consumer wants. In fact it has two different ways of inhibiting rotation. This is sometimes desired when the lens doesn't have a “hard stop” in the focus ring. Adjusting the “rotation stop” works as follows:

1. Pull the Rotation lock knob out in the direction of the arrow.
2. Rotate the Rotation lock knob to one of the three indicated positions. The three positions are:
 - ○ Free, this position allows full rotation of the Rotation knob
 - ○ Stop, this position allows for a rotation of approximately. 350 degrees.
 - ◡ Half, this position allows for a rotation of approximately. 180 degrees.
3. Release the spring-loaded Rotation lock knob so that it “clicks” into one of the three preset positions.

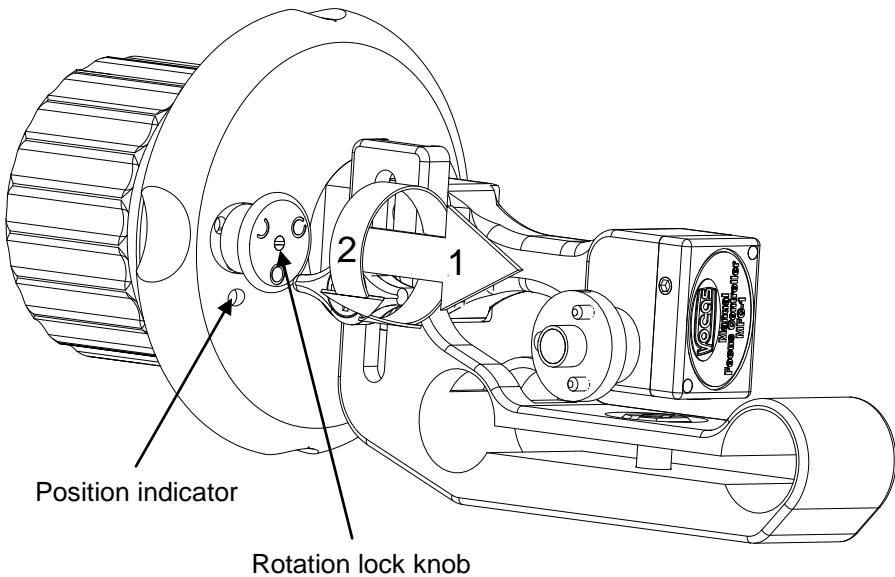

Accessories:

For all available accessories and compatibilities please check our website:

www.vocas.com

Contact data:

Vocas Systems B.V.

Larenseweg 121

1221 CL Hilversum-Netherlands

T:+31(0)35-6233707 F:+31(0)35-6233997

www.vocas.com