

SHOULDER RIG (BASE)

Included:

(2) 1/4-20x3/8 socket cap 

(2) 1/4-20x3/4 button head 

3/16 allen wrench 

5/32 allen wrench 

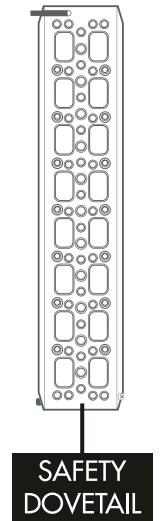
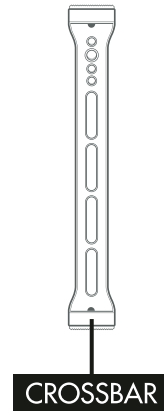
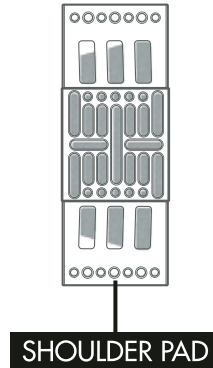
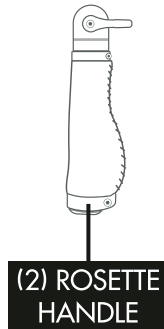

INSTALLATION

1. Select **DOVETAIL**, locate **SAFETY LATCH** and find noted **1/4 HOLES** as shown below
2. Select and locate **SIDE A** of **SHOULDER PAD** to find noted **1/4-20 HOLES** as shown below

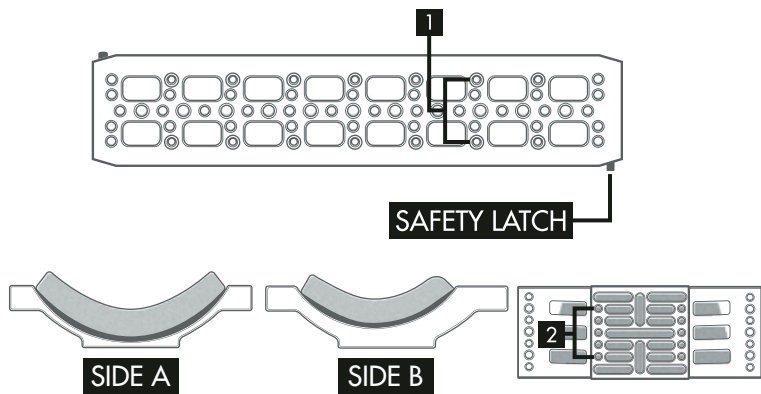

3. With **SIDE A** facing **SAFETY LATCH**, align **DOVETAIL** over **SHOULDER PAD** as shown below, select **1/4-20x3/8 SOCKET CAPS**, tighten with allen wrench
4. Select **CROSSBAR** and **1/4-20x3/4 SCREWS**, align components as shown, tighten to **DOVETAIL** with allen wrench

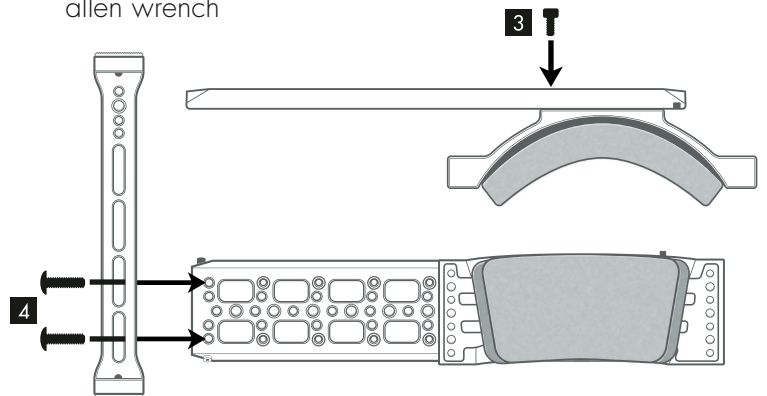

5. Select **HANDLES**, attach to **CROSSBAR** using **THUMB SCREWS**

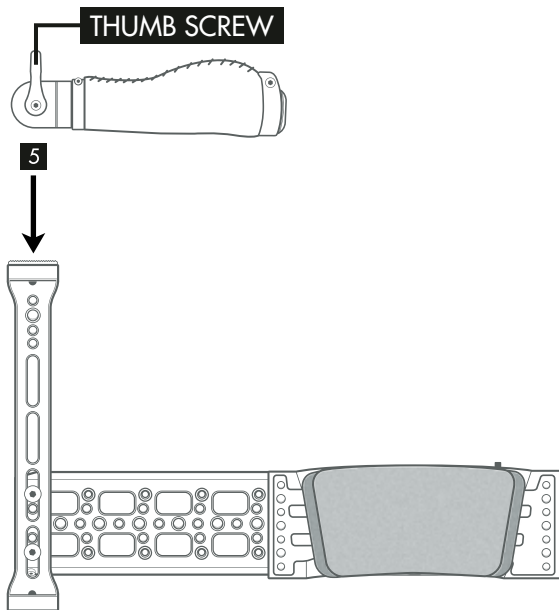

6. Loosen **THUMB SCREWS** to adjust **HANDLES** to desired position

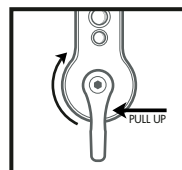
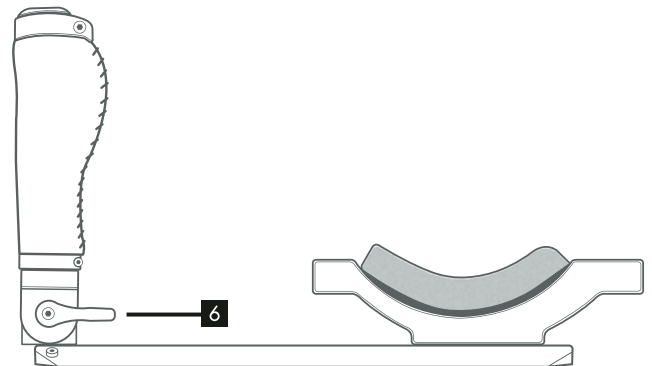

NOTE: THUMB SCREWS can be adjusted by pulling upward and turning to desired position