

WOODEN CAMERA®

2017 SPRING PRODUCT GUIDE

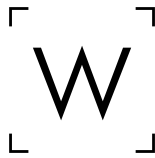

WOODENCAMERA.COM
855.966.3226

UNIVERSAL FOLLOW FOCUS

UFF-1 Universal Follow Focus is the first follow focus to be compatible with 15mm LVV, 15mm Studio, and 19mm rods without the use of adapters. Simply unlock the rod clamps and slide to the appropriate position. Notches in the bottom of the bridge indicate when the clamp is in the perfect position. The included swing arm can be reversed to the front or back position which is helpful for compact lens configurations and the bridge has the lowest height in the industry so it will work with the larger zoom lens barrels. Each hand wheel includes a standard marking disc and a hard stop disc which provides positionable limits when using DSLR lenses with infinite barrel rotation. The hand wheels are removable and have standard accessory ports for whip and crank. Included in the kit are 5 gear attachments: .5 mod for Canon ENG, .6 mod for Fujinon ENG, .8 mod small diameter / .8 mod large diameter for cinema lenses, and a friction gear for DSLR lenses. Each kit ships in custom cut foam which fits natively into a Pelican 1500 case (not included).

UFF-1 UNIVERSAL FOLLOW FOCUS (PRO)

\$1,995 SKU: 244500



UFF-1 UNIVERSAL FOLLOW FOCUS (BASE)

\$1,250 SKU: 244400

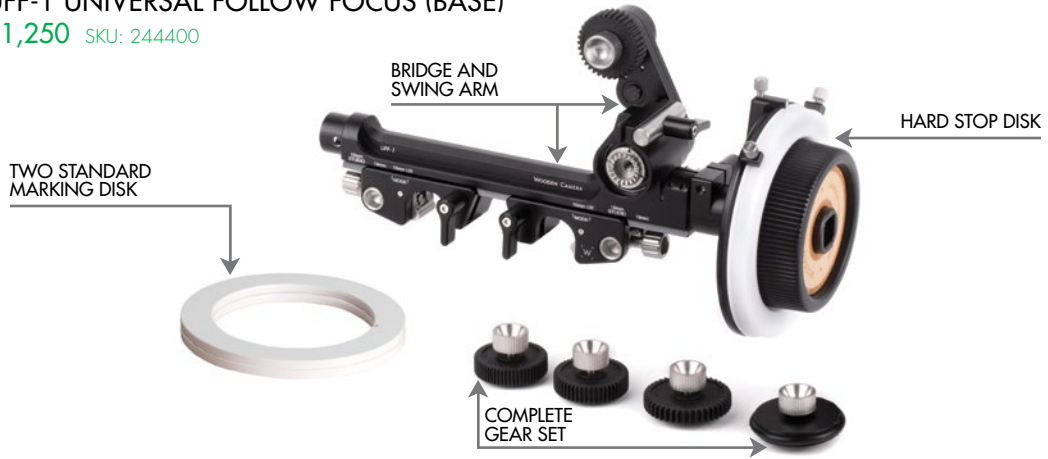

ZIP BOX

ZIP BOX 138mm ROUND

Zip Box 138mm Round holds one 138mm filter or diopter and clamps to the front of lenses. Available in four exterior lens diameter sizes: 80 to 85mm, 90 to 95mm, 100 to 105mm, and 110 to 115mm.



ZIP BOX 138mm ROUND (80-85mm)

\$125 SKU: 242000

ZIP BOX 138mm ROUND (90-95mm)

\$125 SKU: 242100



The lens shade design allows for even the widest lenses and sensor sizes to be covered without vignetting.



ZIP BOX 138mm ROUND (100-105mm)

\$125 SKU: 242200

ZIP BOX 138mm ROUND (110-115mm)

\$125 SKU: 242300



Stainless steel components and unibody rubber design are very durable and stand up to the toughest conditions.

Zip Box is extremely lightweight and weighs about the same as the filter it holds which makes it perfect for gimbal and drone use.



ZIP BOX DOUBLE

Zip Box Double 4x5.65 holds two 4x5.65" (100x144mm) filters and clamps to the front of lenses. Available in four exterior lens diameter sizes: 80 to 85mm, 90 to 95mm, 100 to 105mm, and 110 to 115mm.

ZIP BOX DOUBLE 4X5.65 (80-85mm)

\$125 SKU: 241600



ZIP BOX DOUBLE 4X5.65 (90-95mm)

\$125 SKU: 241700



ZIP BOX DOUBLE 4X5.65 (100-105mm)

\$125 SKU: 241800



ZIP BOX DOUBLE 4X5.65 (110-115mm)

\$125 SKU: 241900



ZIP BOX ADAPTER RINGS

With the Zip Box Adapter Rings, almost every small DSLR lens can be adapted like the Sony E and MFT mount lenses.

\$29 SKU: 231900



ADAPTI SIZES:

49mm	52mm	55mm	58mm
62mm	67mm	72mm	77mm

ZIP BOX FLAG SET (TOP AND SIDES)

Includes three clip on flags compatible with all Zip Boxes (4x4, 4x5.65, and 138mm Round). The flags are made of a lightweight plastic material and clip securely without tools.

\$75 SKU: 242500



UNIFIED DSLR CAGE

Unified DSLR Cage takes the best features from our original DSLR system and adds compatibility for the new Sony and Panasonic XLR interfaces on top of the camera. The open shoe mount area allows for the XLR adapter to be installed without obstruction. Cage includes a folding and reversible top handle which can be repositioned over the lens area, an HDMI lock, integrated lens adapter support, Manfrotto video dovetail quick release, dovetail receiver plate, and an anti-twist design holds the camera firmly in place.

The optional 1.5mm baseplate provides height adjustable 1.5mm rods and on the bottom is an ARRI standard dovetail interface with included quick release dovetail for attaching to a tripod plate when an ARRI dovetail is not in use.

UNIFIED DSLR CAGE (SMALL)

\$299 SKU: 243600

UNIFIED DSLR CAGE (MEDIUM)

\$299 SKU: 243700

UNIFIED DSLR 1.5mm BASEPLATE

\$199 SKU: 243800



ULTRA ARM

ULTRA ARM COMPONENTS

Attaches and holds LCDs and other accessories using standard 25mm ball mounts. Tool-less design lets you quickly attach to 1/4-20 or 3/8-16 threaded holes. Super Clamp version available for attaching to rods, C-stands, or even holding microphones on the end of an arm. Hot Shoe attachment is great for DSLRs and NATO Clamp version works with all existing NATO accessory rails!

ULTRA ARM BALL (3/8-16)

\$39 SKU: 232400



ULTRA ARM BALL (1/4-20)

\$39 SKU: 232300

ULTRA ARM BALL (SUPER CLAMP)

\$85 SKU: 233100

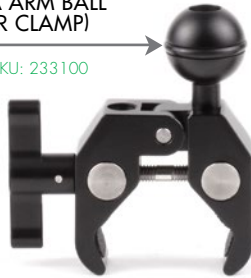

ULTRA ARM BALL (HOT SHOE)

\$45 SKU: 233000



ULTRA ARM BALL (NATO CLAMP)

\$55 SKU: 232900

ULTRA ARM DOUBLE BALL (3")

\$35 SKU: 232600



ULTRA ARM DOUBLE BALL (5")

\$45 SKU: 232700



ULTRA ARM DOUBLE BALL (8")

\$55 SKU: 232800



ULTRA ARM MONITOR MOUNTS

Available in three sizes and are named after the center extension length. 1/4-20 versions are shown but 3/8-16 versions are also available. A fourth version called the Mini Monitor Mount is available with no extension and functions as an easy way to position a monitor close to the camera.

ULTRA ARM MINI MONITOR MOUNT (1/4-20 TO 1/4-20)

\$95 SKU: 233200



ULTRA ARM MONITOR MOUNT (1/4-20 TO 1/4-20, 5")

\$175 SKU: 232100



ULTRA ARM MONITOR MOUNT (1/4-20 TO 1/4-20, 3")

\$165 SKU: 232000



ULTRA ARM MONITOR MOUNT (1/4-20 TO 1/4-20, 8")

\$185 SKU: 232200



UNIVERSAL MATTEBOX

Every Universal Mattebox comes standard with two rotating 4x5.65 filter stages (with an optional third stage available), individual tray catchers, folding French flag, 143mm diameter opening, and NATO standard accessory rails on left, right, and top for attaching accessories. The UMB-1 is designed to be user upgradeable and quick to transition from clamp to swing away to ultralight when using a stabilizer. A Pro version is available for \$1,995 (SKU: 202100), which includes the Swing Away kit, plus all clamp sizes, bottom and side flags.

UNIVERSAL MATTEBOX (SWING AWAY)

ARRI style rubber bellows with integrated 138mm round filter holder. Native 114mm bellows opening with snap in reduction rings in 110, 104, 95, 87, and 80mm diameters. Universal cloth donut included for non-standard lens diameters. Swing away bracket allows mattebox to be unlocked, rolled forward, and opened 90°. Attaches natively to 15mm LW rods and adaptable to studio rods.

\$1,495 SKU: 202000

INSERT SIZES:

80mm 104mm
87mm 110mm
95mm



CLOTH DONUT INCLUDED



UNIVERSAL MATTEBOX (15mm STUDIO ADAPTER)

Attaches to bottom of UMB-1 Base and Swing Away models to clamp to 15mm studio spaced rods. Also compatible with ARRI MB-20 and similar models.

\$175 SKU: 202700



UNIVERSAL MATTEBOX (19mm ADAPTER)

Attaches to bottom of UMB-1 Base and Swing Away models to clamp to 19mm studio rods. Also compatible with ARRI MB-20 and similar models.

\$175 SKU: 202600



UNIVERSAL MATTEBOX

UNIVERSAL MATTEBOX (CLAMP ON)

Clamp on version attaches natively to 143mm diameter lens fronts and includes adapters for 136, 134, 125, 114, 110, 104, 95, 87, and 80mm lens diameters. Can be converted to single stage with no sun shade for an ultralight, stabilizer configuration.

\$1,250 SKU: 201900

CLAMP SIZES:

- 80mm
- 87mm
- 95mm
- 104mm
- 110mm
- 114mm
- 125mm
- 134mm
- 136mm



UNIVERSAL MATTEBOX (BASE)

The most cost effective mattebox kit. Includes a height adjustable 15mm LV rod bracket which can be adapted to studio rods and a universal cloth donut with easy to grab finger loops. Upgradeable to Swing Away or Clamp On versions when needed.

\$995 SKU: 201800



UMB-1 HARD MATTE SET

Snaps into any version of the UMB-1 to mask off lighting. Includes 5 sizes for various focal lengths, and one solid matte to prevent dust from entering lens area between takes.

\$195 SKU: 213600



UNIVERSAL MATTEBOX (SIDE FLAGS, LEFT & RIGHT)

Adjustable side flags compatible with any model of Universal Mattebox.

\$150 SKU: 202200



UNIFIED BASEPLATE



SLOTTED DESIGN FOR 1/4-20 & 3/8-16 CAMERA SCREWS

VERTICAL 15mm ROD CLAMP

For optional lens support, reverse dovetail position.

TOP DOVETAILS AVAILABLE FOR EVERY CAMERA TYPE

ARCA SWISS STANDARD DOVETAIL SHAPE



PASS THROUGH 15mm RODS



DUAL 15mm ROD CLAMPS

ARRI STANDARD DOVETAIL SLOT



QUICK RELEASE DOVETAIL

For attaching to tripod or ARRI standard bridgeplates.

UNIFIED BRIDGEPLATE (19mm)

\$499 SKU: 223100



SLOTTED DESIGN

For attaching to non-standard screw spacing.

ADJUSTABLE CENTER PLATFORM

Set bridgeplate to correct ARRI or RED lens height.



2060 DOVETAIL (12")

\$399 SKU: 143600

UNIFIED VCT



UNIFIED BASEPLATE (SONY FS7)

\$499 SKU: 222100

ADJUSTABLE COUNTERBALANCE VIA DOVETAIL

ALL UNIFIED BASEPLATES ARE COMPATIBLE

UNIFIED VCT WEDGE PLATE

\$495 SKU: 223300

SAFETY STOPPER



ARRI STANDARD ROSETTES AND ACCESSORY MOUNTS

SPRING LOADED FOOT

VCT-14 STANDARD RECEIVER



UNIFIED VCT-14 TRIPOD PLATE

\$295 SKU: 223400

ALL METAL CONSTRUCTION

SHOULDER RIGS

SHOULDER RIG V2 (PREMIUM, BROWN LEATHER)

\$1,495 SKU: 204000

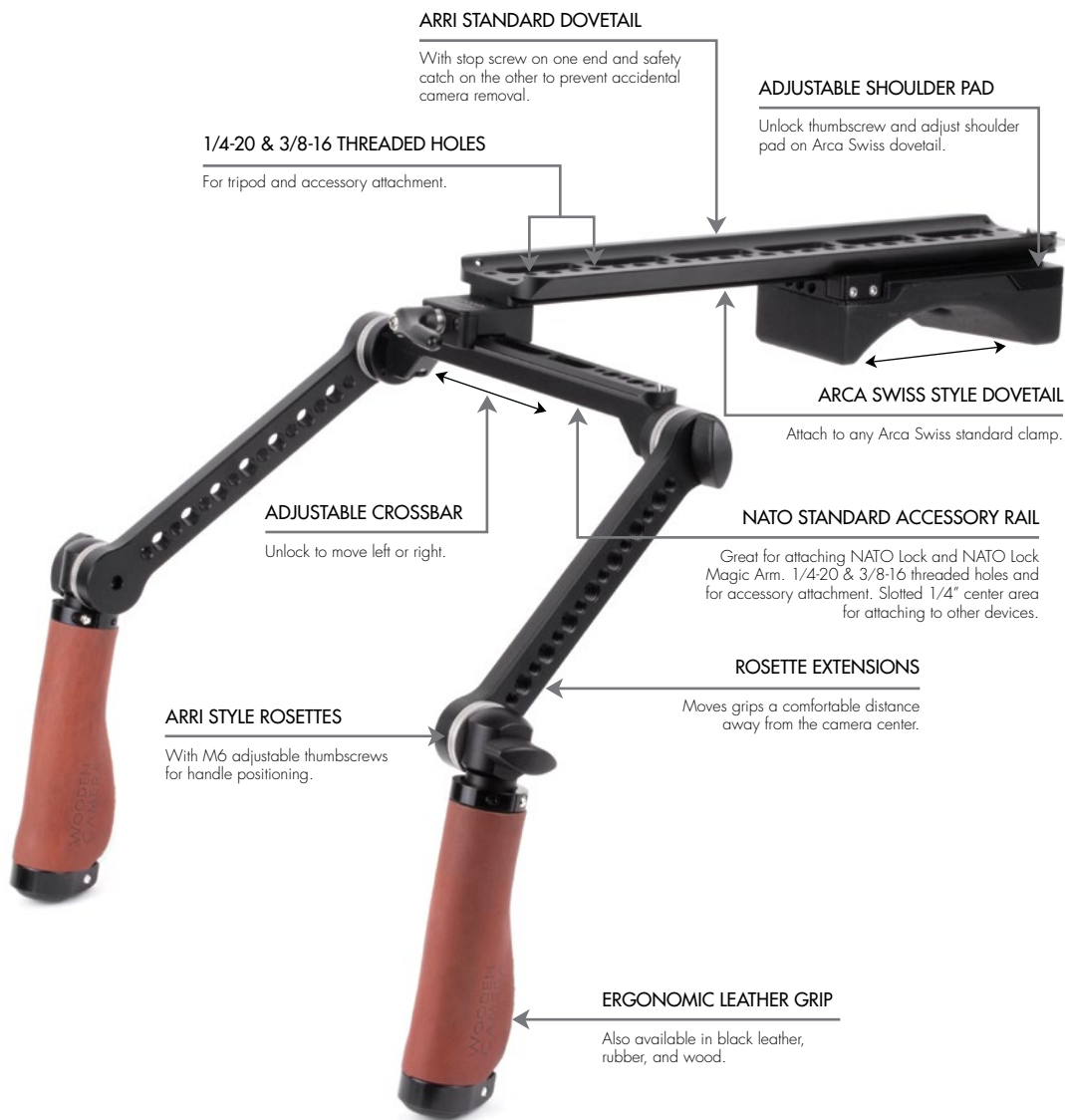

ADDITIONAL OPTIONS

CRUISER
(RUBBER)



\$795 SKU: 161800

SHOULDER RIG V2
(BASE, BLACK LEATHER)



\$995 SKU: 203300

SHOULDER RIG V2
(MID, WOODEN GRIP)



\$1,250 SKU: 223700

WOODEN HANDGRIPS

WOODEN CAMERA HANDGRIPS (RIGHT & LEFT)

These ergonomic wooden handgrips are carved from a solid piece of Sapele wood which is similar to Mahogany. Attaches by ARRI standard rosette and M6 threaded thumbscrew.

HANDGRIP (LEFT)

\$195 SKU: 219400



HANDGRIP (RIGHT)

\$195 SKU: 219300



WOODEN CAMERA HANDGRIP TRIGGER BOX

The control box attaches to the Wooden Handgrips to add start/stop functionality for LANC and ARRI 3 pin Fischer compatible cameras. The same control box works with both the Left and the Right grip. Coiled LANC and Fischer cables are included. No power is required.

\$195 SKU: 219500



INCLUDED CABLES:

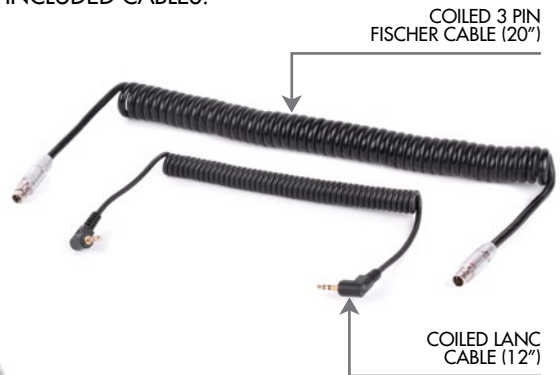

C-BOX (CONVERTER)

C-Box (Converter) allows for HDMI or HD-SDI signal input and simultaneous output of three HD-SDI and two HDMI. Additionally, 5V mini USB port provides power to wireless HDMI "stick" transmitters like Paralinx, IDX Cam-Wave, etc. Three versions available.

C-BOX (CONVERTER, D-TAP)

Shown below. Attaches between existing power plate and mount system (Quick Back, Battery Slide, etc.)

\$599 SKU: 176200

C-BOX (CONVERTER, V-MOUNT)

Male V-Mount on one side, female V-Mount on the other. Attaches between V-Mount battery and V-Mount plate on camera.

\$699 SKU: 176300

C-BOX (CONVERTER, GOLD MOUNT)

Male Gold Mount on one side, female Gold Mount on the other. Attaches between Gold Mount battery and Gold Mount plate on camera.

\$699 SKU: 176400

5V USB OUTPUT

For wireless transmitters etc.

TWO SIMULTANEOUS HDMI OUTPUTS

Great for wireless transmitters like PARALINX, IDX Cam-Wave, etc.

12-24V INPUT MINI 4 PIN XLR

THREE SIMULTANEOUS 3G HD-SDI OUTPUTS

CHOOSE HDMI OR HD-SDI INPUT

V-MOUNT & GOLD MOUNT THREADED HOLE PATTERNS

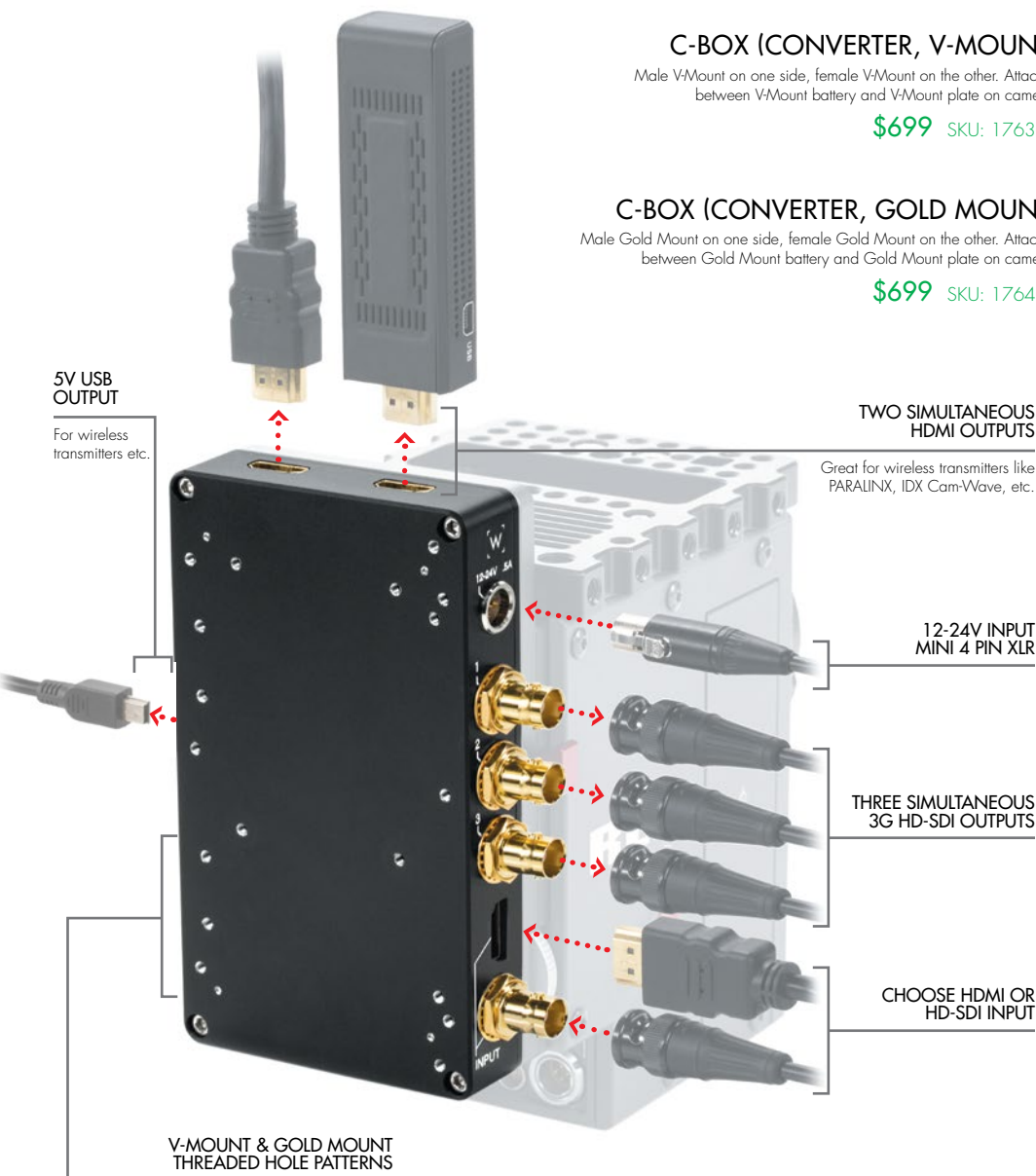

D-BOX (POWER DISTRO)

D-BOX (2 PIN LEMO KIT, D-TAP)

One of the most popular combinations of connectors including (2) 2 Pin LEMO compatible connectors, (2) D-Tap, (1) USB, and a 4 Pin Mini XLR Input. An included pigtail cable loops around from the user's power plate D-Tap (not included) and plugs into power input.

\$449 SKU: 200000

D-BOX (2 PIN LEMO KIT, V-MOUNT)

Similar to the D-Tap version above but with a male V-Mount on one side and female V-Mount on the other. Power is passed internally to breakout connectors and also passed through to camera. Data information is passed when present. (1) D-Tap integrated on the male power plate, (2) 2 Pin LEMO compatible connectors, (2) D-Tap, (1) USB, and (1) Blank.

\$549 SKU: 200100

D-BOX (2 PIN LEMO KIT, GOLD MOUNT)

Male Gold Mount on one side and female Gold Mount on the other. Power is passed internally to breakout connectors and also passed through to camera. (1) D-Tap integrated on the male power plate, (2) 2 Pin LEMO compatible connectors, (2) D-Tap, (1) USB, and (1) Blank.

\$549 SKU: 200200

D-BOX (PROJECT BOX)

Have an idea for something that could fit between a power plate and your camera? This kit comes with (6) Blank panels and (1) Blank left side panel.

\$275 SKU: 201200

D-Box (Power Distribution) allows for user selectable power outputs including 2 pin LEMO compatible connector, 4 pin LEMO compatible connector, 4 pin Hirose, 3 pin Fischer, D-Tap, and USB. Allows for up to 6 simultaneous outputs with a maximum draw of 10A limited by an easily accessible fuse. Left side panel opens to service fuse and to disconnect and remove connector panels.



BLANK PLATES
ALSO AVAILABLE



4 PIN LEMO

12v unregulated.
RED standard wiring.



Connect and
disconnect easily.

REMOVABLE PANEL

Service fuse and install or
remove connectors.

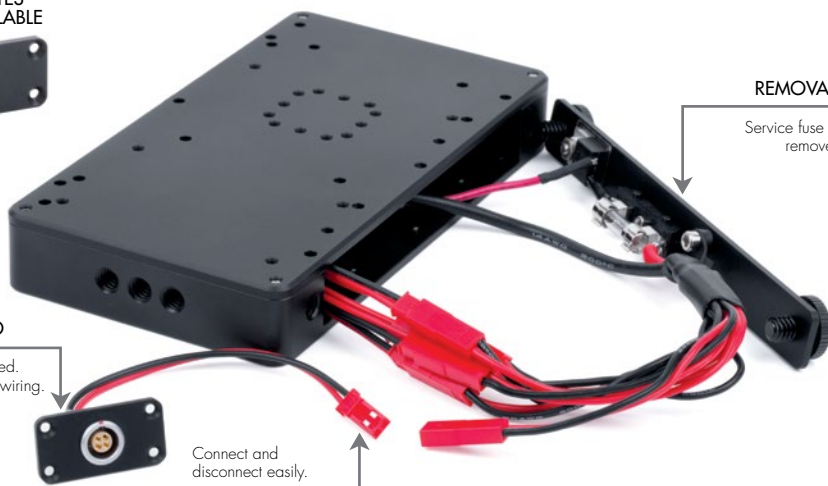

ARRI ALEXA MINI

ARRI ALEXA MINI UNIFIED ACCESSORY KIT (PRO, 19mm)

\$2,940 SKU: 227300

NATO HANDLE KIT (PLUS, 100mm)

Quick release, multifunction top handle attaches and detaches without tools. Ratcheting, 360° rotating grip with integrated shoe mount. Safety NATO Rail (100mm) included in kit.

\$250 SKU: 175800

UVF MOUNT (ALEXA MINI, NO CLAMP)

Attaches directly to NATO Handle (Plus) or any other device with integrated 1.5mm clamp. Accepts ARRI MVF-1 and has three points of adjustment. Tool-less design allows quick installation and removal.

\$379 SKU: 207400

UNIFIED CAGE (ALEXA MINI + LW)

Cage attaches by four screws on top and four screws on the bottom making it extremely secure. Side pieces feature NATO rails and two quick release NATO Rosettes that are ARRI standard. 1.5mm LW baseplate on bottom attaches to any tripod plate or ARRI standard bridgeplate.

\$995 SKU: 226900

BATTERY SLIDE

Adjustable mounting system for V-Mount, QRC style Gold Mount, and RED/Blueshape battery plates.

\$199 SKU: 156600

2x 19mm ROD (15")

19mm diameter iris rods for mounting accessories.

\$60 ea. SKU: 143300

ROD CLAMP (19mm)

Provides 1/4-20 and 3/8-16 mounting points for attaching accessories like Battery Slide to rods.

\$99 SKU: 150400

2060 DOVETAIL (12")

12" ARRI standard dovetail with safety catches on each end.

\$399 SKU: 143600

UNIFIED BRIDGEPLATE (19mm)

ARRI style bridge plate with 19mm studio spacing for holding the two 19mm Rods (15") at the correct lens height and attaches easily to an ARRI standard dovetail.

\$499 SKU: 223100

ADDITIONAL OPTIONS

V-MOUNT (ALEXA MINI)



\$320 SKU: 207500

D-BOX (ALEXA MINI, V-MOUNT)



\$1,195 SKU: 209200

WC GOLD MOUNT (ALEXA MINI)



\$320 SKU: 207600

D-BOX (ALEXA MINI, GOLD MOUNT)



\$1,195 SKU: 209100

BATTERY SWING

Battery Swing provides standard V-Mount and Gold Mount hole patterns for mounting WC battery plates and the D-Box (Alexa Mini). Quickly access the back of the camera by pulling the black pin and swinging open. Mounting bracket has integrated 15mm rod openings and is most commonly used in the lower position for bottom rods. Battery Swing can be mounted to top rods by moving the swing arm to the top row of holes on the battery bracket.

\$350 SKU: 245700

SWING CAN BE INSTALLED ON TOP
WHEN USING TOP 15mm RODS



BLACKMAGIC URSA MINI

BLACKMAGIC URSA MINI UNIFIED ACCESSORY KIT (PRO)

\$1,803 SKU: 226500

NATO HANDLE KIT
(PLUS, 70mm)

\$250 SKU: 175700

UVF MOUNT (NO CLAMP)

\$379 SKU: 179900

TOP PLATE (URSA MINI)

\$295 SKU: 216000

SAFETY DOVETAIL (12")

\$260 SKU: 151200

2x 15mm ROD (15")

\$60 ea. SKU: 142600

UNIFIED BASEPLATE (URSA MINI)

\$499 SKU: 222200

WIRELESS SIDE PLATE ADAPTER
(URSA MINI)

Attaches over the right rear side panel to provide mounting points for the Universal Wireless Side Plate which can be added for wireless receiver boxes, wireless transmitters, etc.

\$49 SKU: 229700

ROSETTE SIDE PLATE
(URSA MINI)

Attaches to the right side of the Blackmagic URSA Mini Camera by the ARRI rosette to add additional 1/4-20 and 3/8-16 mounting points. An ARRI standard rosette is available for attaching the handgrip or extension arm. ARRI accessory mount also available in several places (3/8-16 screw hole with locating pins adjacent).

\$150 SKU: 229600

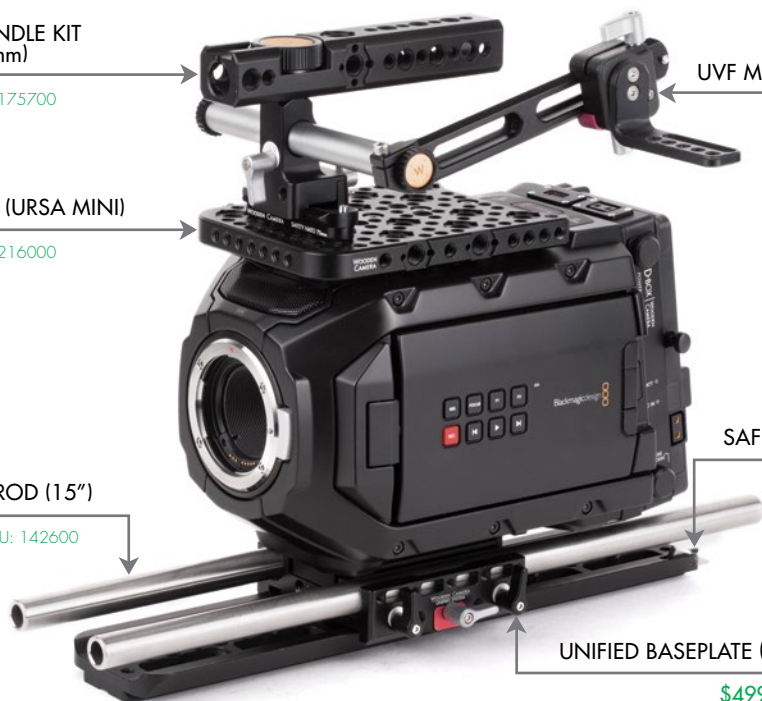

D-BOX (URSA MINI)

D-Box (URSA Mini) is a custom version of our popular D-Box that adds power distribution, standardized remote start/stop, and hot swap abilities for the Blackmagic URSA Mini Pro, EF, PL, B4, etc cameras. The D-Box attaches directly to the back of the camera body using a special Molex connector eliminating external cabling. It also interfaces with the rear LANC port which is how the D-Box controls the camera's run/stop.

D-BOX (URSA MINI, V-MOUNT)

\$995 SKU: 239500

D-BOX (URSA MINI, GOLD MOUNT)

\$995 SKU: 239600



CANON C300mkII

CANON C300mkII UNIFIED ACCESSORY KIT (PRO)

\$2,071 SKU: 226200

NATO HANDLE KIT (CHEESE, 70mm)

Quick release, multi-function top handle attaches and detaches without tools. Arrays of 1/4-20 and 3/8-16 holes provides mounting points for additional accessories. Safety NATO Rail (70mm) included in kit.

\$250 SKU: 166300

TOP PLATE (C300mkII)

Top mounting cheeseplate for the Canon C300mkII camera. Arrays of 1/4-20 and 3/8-16 holes in standard spacing for accessory mounting.

\$195 SKU: 216100

UVF MOUNT (V2)

Attaches to included 15mm tube clamp or any other device with integrated 15mm clamp. Accepts most EVFs and LCDs with three points of adjustment. Tool-less design allows quick installation and removal.

\$449 SKU: 157100

BATTERY SLIDE

Adjustable mounting system for V-Mount, QRC style Gold Mount, and RED/Blueshape battery plates.

\$199 SKU: 156600

ROD CLAMP (15mm LW)

Provides 1/4-20 mounting points for attaching accessories like Battery Slide to rods.

\$99 SKU: 150200

SAFETY DOVETAIL (12")

ARRI standard dovetail with stop screw on one end and safety latch on the other to prevent accidental camera removal.

\$260 SKU: 151200

2x 15mm ROD (15")

15mm diameter iris rods for mounting accessories.

\$60 ea. SKU: 142600

UNIFIED BASEPLATE (CANON C300mkII)

Quick release baseplate that provides lightweight 15mm rod support at the correct lens height.

\$499 SKU: 222100

ADDITIONAL OPTIONS

WC V-MOUNT (C300mkII)



\$225 SKU: 214700

D-BOX (C300mkII, V-MOUNT)



\$1,150 SKU: 215800

WC GOLD MOUNT (C300mkII)



\$225 SKU: 214800

D-BOX (C300mkII, GOLD MOUNT)



\$1,150 SKU: 215700

PANASONIC VARICAM LT

PANASONIC VARICAM LT UNIFIED ACCESSORY KIT (PRO)

\$1,807 SKU: 224100

UVF MOUNT (VARICAM 35, NO CLAMP)

The popular UVF Mount v2 in custom configuration for devices like NATO Handle (Plus) with integrated 15mm clamp. Accepts Panasonic VariCam 35 EVF (AU-VCFV1G OLED CVF) viewfinder with three points of adjustment. Tool-less design allows quick installation and removal.

\$379 SKU: 197500

NATO HANDLE KIT (PLUS, 100mm)

Quick release, multi-function top handle attaches and detaches without tools. Ratcheting, 360° rotating grip with integrated shoe mount. Safety NATO Rail (100mm) included in kit.

\$250 SKU: 175800

TOP PLATE (VARICAM LT)

Top cheeseplate for the Varicam LT. Arrays of 1/4-20 & 3/8-16 holes in standard spacing and ARRI standard accessory mount in several places.

\$299 SKU: 223500

2x 15mm ROD (15")

15mm diameter iris rods for mounting accessories.

\$60 ea. SKU: 142600

SAFETY DOVETAIL (12")

ARRI standard dovetail with stop screw on one end and safety latch on the other to prevent accidental camera removal.

\$260 SKU: 151200

UNIFIED BASEPLATE (VARICAM LT)

Quick release baseplate that provides lightweight 15mm rod support at the correct lens height.

\$499 SKU: 222400

ADDITIONAL OPTIONS

UNIVERSAL LENS SUPPORT (15mm LW)



\$295 SKU: 175400

UNIVERSAL LENS SUPPORT (19mm/15mm STUDIO)



\$295 SKU: 175500

PANASONIC VARICAM 35

PANASONIC VARICAM 35 UNIFIED ACCESSORY KIT (PRO)

\$2,006 SKU: 225900

TOP PLATE (VARICAM 35, BACK)

Top cheeseplate for the Varicam 35 recorder unit (rear camera module). Arrays of 1/4-20 holes in standard spacing and multiple 3/8-16 holes for large accessories. Recessed area for removing remote control.

\$249 SKU: 196300

UVF MOUNT (VARICAM 35, NO CLAMP)

The popular UVF Mount v2 in custom configuration for devices like NATO Handle (Plus) with integrated 1.5mm clamp. Accepts Panasonic VariCam 35 EVF (AU-VCVF1G OLED CVF) viewfinder with three points of adjustment. Tool-less design allows quick installation and removal.

\$379 SKU: 197500

NATO HANDLE KIT (PLUS, 100mm)

Quick release, multifunction top handle attaches and detaches without tools. Ratcheting, 360° rotating grip with integrated shoe mount. Safety NATO Rail (100mm) included in kit.

\$250 SKU: 175800

TOP PLATE (VARICAM 35, FRONT)

Top cheeseplate for the Varicam 35 brain unit (front camera module). Arrays of 1/4-20 & 3/8-16 holes in standard spacing and ARRI standard accessory mount in several places.

\$249 SKU: 196200

2x 15mm ROD (15")

1.5mm diameter iris rods for mounting accessories.

\$60 ea. SKU: 142600

SAFETY DOVETAIL (12")

ARRI standard dovetail with top screw on one end and safety latch on the other to prevent accidental camera removal.

\$260 SKU: 151200

UNIFIED BASEPLATE (VARICAM 35)

Quick release baseplate that provides lightweight 15mm rod support at the correct lens height.

\$499 SKU: 222400

ADDITIONAL OPTIONS

ACCESSORY KIT (BASE)



\$1,237 SKU: 225700

ACCESSORY KIT (ADVANCED)



\$1,547 SKU: 225800

SONY FS7/FS5

NATO HANDLE KIT (PLUS, 70mm)

\$250 SKU: 175700

TOP PLATE (FS7)

\$299 SKU: 193900

2x 15mm ROD (15")

\$60 ea. SKU: 142600

SAFETY DOVETAIL (12")

\$260 SKU: 151200

SONY FS7 UNIFIED ACCESSORY KIT (PRO)

\$2,055 SKU: 224400

UVF MOUNT
(FS7, NO CLAMP)

\$329 SKU: 195800

BATTERY SLIDE

\$199 SKU: 156600

ROD CLAMP
(15mm LW)

\$99 SKU: 150200

UNIFIED BASEPLATE (SONY FS7)

\$499 SKU: 222100

SONY FS5 UNIFIED ACCESSORY KIT (PRO)

\$1,631 SKU: 226800

NATO LOCK MAGIC ARM (11")

\$259 SKU: 198700

TOP PLATE (SONY FS5)

\$195 SKU: 215900

2x 15mm ROD (15")

\$60 ea. SKU: 142600

SAFETY DOVETAIL
(12")

\$260 SKU: 151200

BATTERY SLIDE

\$199 SKU: 156600

ROD CLAMP (15mm LW)

\$99 SKU: 150200

UNIFIED BASEPLATE (SONY FS5)

\$499 SKU: 222400

RED WEAPON/DSMC2

RED MALE LEMO TO FEMALE POGO LCD/EVF CABLE (12", WEAPON)

Converts standard 16 pin LEMO compatible to female pogo interface for the DSMC2 monitors.

\$205 SKU: 221400

ULTRA ARM MONITOR MOUNT (1/4-20 TO 1/4-20, 5")

Articulating arm with two sets of 25mm (1") double ball joints which allow a monitor or accessory to be positioned in just about any orientation. Tool-less 1/4-20 knobs on each end with non-slip rubber pads for easy installation.

\$175 SKU: 232100

UVF MOUNT v2

UVF Mount v2 accepts most EVFs and LCDs with three points of adjustment. Tool-less design allows quick installation and removal UVF v2 Sled. Safety pin prevents accidental removal.

\$449 SKU: 157100

PL MOUNT (EPIC/SCARLET)

Simple PL mount that attaches to Weapon, Epic-W, Scarlet-W, Epic, and Scarlet cameras.

\$399 SKU: 175900

LW 15mm BRACKET (WEAPON)

Combine with Easy Riser for 15mm LW rods on Weapon/Epic-W/Scarlet-W/Raven.

\$140 SKU: 213800

2x SAFETY NATO ARM (WEAPON)

NATO standard rail with safety pins on each end. Spans from Easy Top (Weapon) to Easy Riser (Weapon).

\$140 ea. SKU: 227700

2060 DOVETAIL (12")

12" ARRI standard dovetail with safety catches on each end.

\$399 SKU: 143600

UNIFIED BRIDGEPLATE (19mm)

19mm Bridgeplate with adjustable center platform for correct ARRI or RED lens height. Slotted design allows for attaching to non-standard screw spacing.

\$499 SKU: 223100

ADDITIONAL OPTIONS

PASS THROUGH TOP PLATE (WEAPON/DSMC2)



\$350 SKU: 229400

CABLE-LESS V-MOUNT (WEAPON/DSMC2)



\$645 SKU: 220600

CABLE-LESS GOLD MOUNT (WEAPON/DSMC2)



\$645 SKU: 220800

RED WEAPON/DSMC2

TRIGGER HANDLE (WEAPON)

Attaches directly to camera top or to top plate and 1/4-20 and 3/8-16 holes for attaching accessories. Record button on top.

\$350 SKU: 228000

EASY TOP (WEAPON)

Top cheeseplate for RED Weapon, Scarlet Weapon, and Raven cameras. 1/4-20 and 3/8-16 holes in standard spacing for accessory mounting. Included interfaces convert the two LCD/EVF pogo pins to 16pin LEMO compatible connectors.

\$599 SKU: 213900

D-BOX GOLD MOUNT (WEAPON)

Custom version of our popular D-Box that adds power distribution, standardized remote start/stop, and hot swap abilities for the RED DSMC2 cameras. Tool-less installation utilizing our Cable-less interface which attaches directly to the back of the camera body. Authentic Anton Bauer Gold Mount battery plate.

\$1,295 SKU: 234000

RIGHT SIDE PLATE (WEAPON)

Side mounting cheeseplate for the RED Weapon, Scarlet Weapon, and Raven cameras. Attaches directly to side of camera body. Rows of 1/4-20 threaded holes in RED standard spacing, ARRI style mounting holes, and ARRI standard rosette.

\$150 SKU: 227800

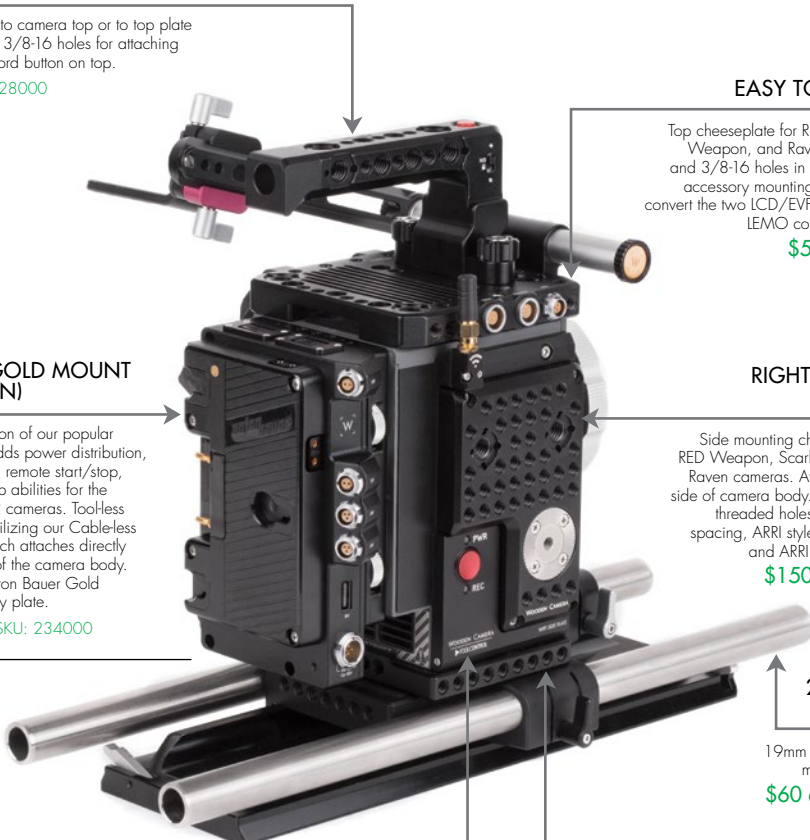

WiFi SIDE PLATE (WEAPON)

Provides an external WiFi antenna mount for the RED DSMC2 cameras and increases the signal range when using apps like FoolControl. Attaches in place of the decorative right side panel and does not interfere with RED products.

\$499 SKU: 228800

2x 19mm ROD (15")

19mm diameter iris rods for mounting accessories.

\$60 ea. SKU: 143300

EASY RISER (WEAPON)

Riser shim plate for RED Weapon, Epic-W, Scarlet-W, and Raven cameras. Combine with Unified Bridgeplate (19mm) or (15mm Studio) for rod support at correct lens height.

\$160 SKU: 213700

12v D-TAP



12v 2PIN LEMO

24v 3PIN FISCHER WITH R/S

5v USB OUTPUT

12-16v HOT SWAP INPUT

D-BOX (WEAPON/DSMC2, V-MOUNT)



\$1,295 SKU: 233900

ADDITIONAL OPTIONS

D-BOX (WEAPON, POWER DISTRIBUTION PORTION ONLY)



\$699 SKU: 235000



WOODEN CAMERA® DIRECTOR'S MONITOR CAGE v2

Engineered to be universally compatible with any monitor up to 9" diagonally with newly designed main brackets also allow direct mounting to the rear of Convergent Design Odyssey and Apollo.

INCLUDES:

- 1 Universal LCD Sunshade
- 2 Padded Neck Strap
- 3 Cable Tie-Wrap
- 4 LCD Offset Brackets
- 5 Teradek/Paralinx Adapter
- 6 Gold Mount & V-Mount Screws
- 7 1/4-20 LCD Mounting Screws
- 8 Convergent Design Mounting Screws
- 9 Teradek Bolt Mounting Kit

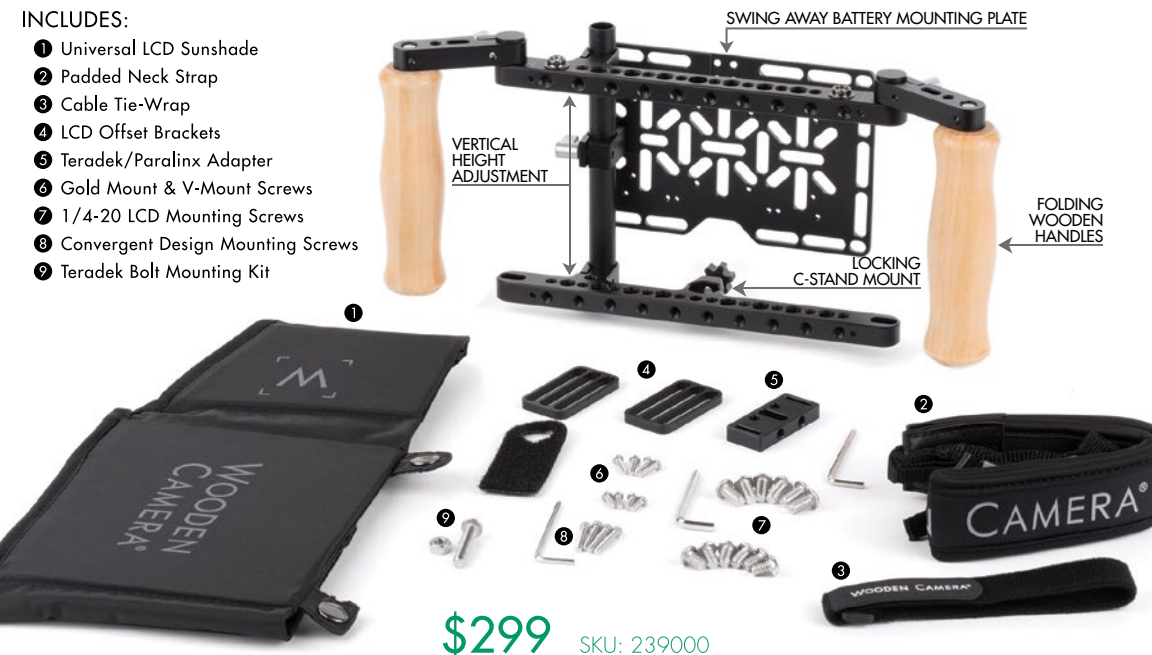

\$299 SKU: 239000

